

# Enhanced Performance of Single-Phase Inverter for Driving Single-Phase AC Motor in Solar-Powered Water Pumping Systems: A Comparative Study on Efficiency

Dimas Cahya Febrianto

Marine Electrical Engineering, Shipbuilding Institute of Polytechnic Surabaya, Indonesia

Correspondence author: dimascahya@student.ppns.ac.id

## ABSTRACT

*Solar-powered water pumps have emerged as a sustainable solution for providing clean water to remote areas where access to the electrical grid is limited. These systems typically require specific components to enhance the voltage from the solar panel to match the voltage rating of the water pump motor. One key component is the inverter, which converts the direct current (DC) from the solar panel into alternating current (AC) suitable for driving the motor. This paper proposes a novel approach using a single-phase boost inverter for solar water pumping systems, designed to efficiently increase and convert DC to AC voltage without the need for a transformer. The inverter utilizes Sinusoidal Pulse Width Modulation (SPWM), implemented through an Arduino Uno microcontroller, ensuring smooth and efficient voltage conversion. The proposed inverter design is tested using a 300W solar panel in a clean water supply system for mosques, demonstrating satisfactory results in terms of efficiency and functionality. The testing confirms that the system is capable of supplying clean water at a consistent rate, with the inverter effectively boosting the panel voltage to match the pump's required motor voltage. These findings highlight the potential of the proposed single-phase boost inverter for improving the overall performance and cost-effectiveness of solar-powered water pumps, offering a viable solution for off-grid water supply systems.*

**Key Word:** *Water pump, solar power, clean water supply, solar panel*

## I. INTRODUCTION

Access to clean water is a fundamental human need and an essential resource for daily life. In many regions, especially in rural or remote areas, obtaining a reliable water supply remains a significant challenge [1]. One such example is places of worship, such as mosques, where access to clean water for essential activities like ablution is often limited. Ablution is a prerequisite for prayer in these places, making the availability of clean water for this purpose crucial. Traditionally, clean water for these purposes is sourced from wells and pumped using electric water pumps. However, in some areas, this process faces several challenges [2][3].

In regions without a stable electrical supply or where frequent disruptions to the electrical grid occur, providing a reliable source of clean water becomes increasingly difficult. When the electricity is unavailable or intermittent, mosque caretakers are forced to manually fetch water for ablution, a process that is not only inconvenient but also time-consuming. This issue is particularly concerning as it can interfere with the spiritual activities of the community, potentially diminishing the accessibility and availability of worship spaces.

To address these challenges, this paper proposes a sustainable solution in the form of a solar-powered water pump system. This system is designed to function autonomously, providing a continuous

supply of clean water for mosques and other similar places of worship, irrespective of the reliability of the local electricity grid. Solar power serves as a reliable alternative energy source, especially in areas with frequent electricity outages, as it harnesses the abundant natural energy from the sun, which can be utilized for pumping water without requiring a conventional power grid connection[4][5].

While solar-powered systems have proven to be an effective solution in various applications, their implementation in off-grid, rural areas has been particularly impactful. Despite being a relatively small-scale power source, solar technology has been successfully used to address energy and water supply issues in underserved communities. By providing a solar-powered pump system, mosques can maintain a steady and clean water supply for ablution and other purposes, enhancing the convenience and well-being of their congregants.

Given the frequent disruptions in the electricity network and the increasing need for sustainable solutions, this study investigates the design and implementation of a solar water pumping system that operates efficiently even in areas with unreliable electrical infrastructure. The paper aims to explore the performance of the proposed system and its potential to alleviate the challenges associated with water access in off-grid areas, thus supporting the continued use and accessibility of places of worship.

## II.METHODOLOGY

### 1. Design for a Solar-Powered System

When designing a solar-powered water pump system, several factors must be considered for optimal performance, including the type of motor, pump capacity, well depth, and the solar panel system's capacity [6][7][8]. Small-scale

water pumps typically use single-phase AC induction motors, but since solar panels generate DC voltage, an inverter is needed to convert the DC to the AC voltage required by the motor.

The motor usually operates at 220V AC, common in countries like Indonesia, but the DC voltage from the panels is often lower. Therefore, a voltage boost is necessary to match the motor's requirements. Different power converters, such as DC-DC boost converters and single-phase inverters, have been developed [9]. Some systems use both a DC-DC converter and a single-phase inverter, while others use simpler configurations, like single-phase bridge inverters [10] or amplifier inverters, which may include transformers.

The main advantage of the single-phase boost inverter is its simplicity and cost-effectiveness, as it eliminates the need for additional components like transformers [11]. This study focuses on this inverter type, which efficiently boosts and converts the solar panel's DC output to the required AC voltage for the motor.

A challenge in solar-powered systems is the fluctuation in solar panel voltage due to environmental factors, while the pump motor requires stable voltage for efficient operation. Voltage regulation is achieved through Sinusoidal Pulse Width Modulation (SPWM), implemented using an Arduino Uno microcontroller [12]. By adjusting the reference voltage, the output of the boost inverter is fine-tuned to match the motor's needs.

To ensure continuous water supply, even when the sun isn't shining, an energy storage solution is necessary. This study uses a water tank-based storage system. The pump fills the tank during the day, and a float switch prevents overflow by disconnecting the pump when the tank is full, ensuring efficient water storage and

availability even at night or during cloudy periods [13][14].

## 2. Unit

This research focuses on the design and evaluation of a single-phase boost inverter for use in a solar-powered water pumping system. The primary function of the inverter is to convert the DC voltage generated by the photovoltaic (PV) panels into the AC voltage required to operate the water pump motor. The inverter employs boost modulation technology, which is based on Sinusoidal Pulse Width Modulation (SPWM), and is implemented using the Arduino Uno microcontroller. This configuration ensures the efficient conversion of energy, optimizing the performance of the system even under variable solar radiation conditions[15].

A float switch is integrated into the system to provide automated control of the pump, adjusting its operation based on the water level in the storage tank. This feature guarantees that the pump functions only when necessary, preventing wastage and maintaining efficient operation. The schematic diagram (Figure 1) outlines the key components and their interconnections in the system. The setup includes the solar panel array, boost inverter, a single-phase induction motor driving the centrifugal water pump, the float switch, an Arduino Uno microcontroller, and a computer interface used for programming the Arduino to control the system's operation [16].

The solar-powered water pump system is designed to convert solar energy into electrical power, which is then used to drive the water pump motor. In this study, a single-phase induction motor was selected due to its cost-effectiveness and widespread use in small-scale water pumping applications. As the solar panels produce DC voltage, but the water pump requires AC voltage, a single-phase boost inverter is employed to efficiently convert the DC voltage into the necessary AC supply for the pump motor. The inverter's output voltage is controlled by modulating

the pulse width of the signal from the Arduino Uno, utilizing the SPWM method. This modulation strategy ensures that the output voltage remains stable despite fluctuations in solar irradiance and ambient temperature that can affect the panel's performance [17][18].

The inclusion of an energy storage system is a critical component for ensuring the reliability and continuous operation of the water pump, even when sunlight is not available. In this case, the storage medium is a water tank. The pump operates to fill the water tank, and the float switch automatically controls the pump's operation based on the water level. Once the tank reaches its maximum capacity, the float switch disconnects the inverter from the motor, preventing overflow and ensuring the system's longevity and optimal performance [19]. This energy storage mechanism is an important feature that enhances the practicality and scalability of the solar-powered water pump, particularly in locations with intermittent or unreliable power supply.

The solar panels in the system are composed of solar cells connected in both series and parallel configurations. These panels generate both voltage and current, with the output varying in response to changes in light intensity and temperature [20]. The single-phase boost inverter, which utilizes two DC-DC boost converters, is responsible for both stepping up the voltage and converting the DC from the solar panels into AC for the water pump motor. This dual function ensures that the system operates with high efficiency and provides sufficient power to the motor, even under variable sunlight conditions. The boost inverter plays a crucial role in maintaining the system's efficiency and cost-effectiveness, particularly in off-grid applications where access to a reliable electrical grid may be limited [1].

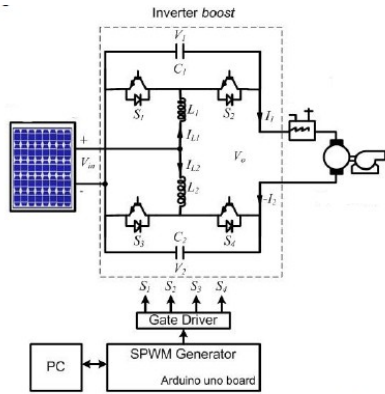

Figure 1. inverter boost schema

### III.RESULT & DISCUSSION

#### 1.Result

The single-phase boost inverter design for a solar water pump was verified in two stages: the first stage included simulation using PSIM software, and the second stage involved performing tests in a laboratory environment.

##### A. Simulation PSIM

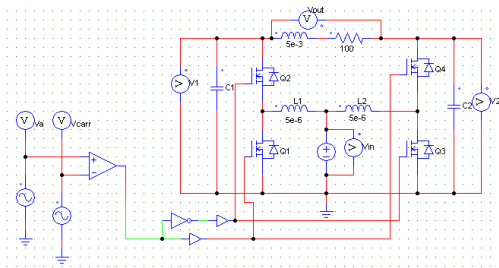

Figure 2. schema on PSIM

The boost inverter circuit design presented in this study incorporates two DC-DC boost converters arranged in opposite directions. Each converter consists of two active switching elements in the form of Insulated-Gate Bipolar Transistors (IGBTs), along with an inductor and a capacitor. In the simulation model, an input voltage of 12 Volts is applied to the circuit, with a 100 Ohm resistor and a 5 mH inductor used as the load. The simulation results for the boost inverter are obtained using PSIM software, and the output waveforms are illustrated in Figure 3. Presents the input voltage waveform of the boost inverter, which is a DC voltage of 12 Volts, alongside the output voltage waveform, which closely resembles

a sinusoidal waveform. Additionally, the voltage waveforms of the two DC-DC boost converters are shown, and the SPWM pulse wave is depicted.

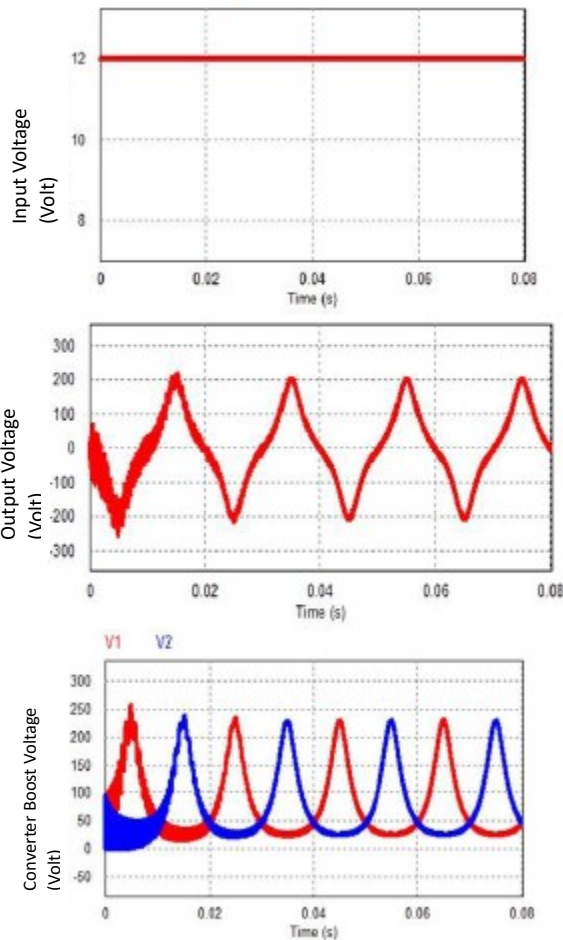

Figure 3. schema on PSIM

The simulation results reveal that the boost inverter is capable of generating an alternating voltage with a near-sinusoidal waveform, achieving an RMS voltage of 126 Volts. This indicates that the design of the single-phase boost inverter is both effective and accurate, aligning with the expected performance criteria. The validity of the inverter's operation is further confirmed by the waveforms of the two DC-DC boost converters, which show opposite phase relationships. This phase opposition between the converters is critical for generating an alternating output voltage. The inverter's ability to produce this alternating voltage is a testament to the robustness and reliability of the boost inverter design.

## B. Hardware test result

Table 1. Hardware parameter

Parameter	Value
Input voltage (Volt)	12
Induktor (mH)	1
Capasitor ( $\mu$ F)	0,47
Load resistor (Ohm)	120
Switching Frequency (KHz)	31
Output frequency (Hz)	50
Input voltage (Volt)	12

The single-phase boost inverter system, was experimentally evaluated with an input voltage of 12 Volts supplied by a battery and an output resistance of 120 Ohms. The testing procedure was conducted using an analog oscilloscope, and the resulting waveforms are presented in Figure 4.

Figure 4(a) illustrates the sinusoidal output waveform of the inverter, with an RMS voltage value of 140 Volts. This result confirms that the inverter successfully converts the DC input voltage into AC voltage, producing an output voltage greater than the input voltage, thereby achieving the boosting effect. The inverter functions by efficiently transforming the DC voltage into AC voltage, while simultaneously increasing the output voltage, as intended by the system's design.

This positive outcome is directly correlated to the effective performance of the two DC-DC boost converters that comprise the boost inverter. Evidence of this can be seen in the second voltage waveform of the DC-DC boost converters in Figure 4(b). As depicted in Figure 4(a), the waveforms of the two

converters are in phase opposition, and when compared, they generate a stable AC output voltage, which is essential for driving the single-phase AC motor.

The successful operation of these two DC-DC boost converters is inextricably linked to the modulation efficiency of the switching mechanism. The sinusoidal pulse-width modulation (SPWM) technique, which is implemented through the Arduino microcontroller, plays a crucial role in generating the correct PWM pulses at the MOSFET gate driver, as shown in Figure 4(c). These pulses regulate the switching actions of the converters, ensuring that the output voltage remains stable and efficiently converted.

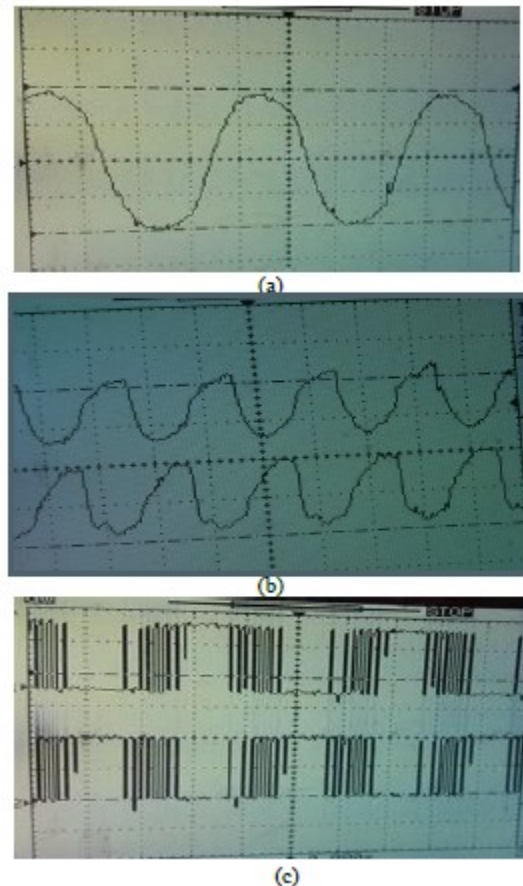

Figure 4. (a) Output voltage (b) Converter boost voltage and (c) PWM Pulse

Table 1. describes the component parameters used

Component	Parameter	Value
<b>Solar cell</b>	$P_{max}$ (Watt-Peak)	300
	$V_{mpp}$ (Volt)	37
	$I_{mpp}$ (Amp)	45
	$V_{oc}$ (Volt)	45
	$I_{sc}$ (Ampere)	8,8
	Total cell	72
<b>Water Pump</b>	$P$ (Watt)	125
	$V$ (Volt)	220
	$I$ (Ampere)	1,3
	Head max (meter)	20
	Suction pipe (mm)	25
	Push pipe(mm)	25
<b>Water tank</b>	Frequency (Hz)	50
	Containt (liter)	1000

The data acquired using the Fluke 41 PowerHarmonic Analyzer reveals that the solar panel output voltage is 34 Volts under operational conditions. When the single-phase boost inverter is powered by this solar panel and connected to a water pump motor load, it successfully generates a sinusoidal AC output voltage of 222 Volts RMS, which aligns with the rated voltage required for the water pump motor. This confirms that the inverter is efficiently supplying the necessary voltage to drive the motor.

Additionally, the analysis of the Total Harmonic Distortion (THD) of the output voltage shows a remarkably low value of 0.51%, indicating that the inverter produces a high-quality output with minimal harmonic distortion. The current waveform corresponding to the inverter output is also nearly sinusoidal, further

validating the high efficiency of the inverter.

When the inverter is powering the water pump motor, it provides a current of 0.89 Amps, with the current waveform exhibiting a THD of 22.35%. These findings demonstrate that the single-phase boost inverter not only meets the voltage requirements of the motor but also ensures that the power delivered is both efficient and stable. Furthermore, the system is capable of powering the motor using a 300W photovoltaic (PV) panel, making it a cost-effective and efficient solution for solar-powered water pumping applications.

The performance of the single-phase boost inverter is shown in Figure 5. During water pump operation, the inverter provides 153 watts of output power, a power factor of 0.78, an RMS voltage of 222 volts, and a frequency of 49.97 Hz, matching the water pump motor's specifications. The inverter successfully converts DC power from the solar panel into AC, meeting the motor's voltage and frequency needs. This robust design ensures reliable operation, even with fluctuating solar energy.

The system also includes an automated control with a float switch in the water tank. When the tank is low, the switch activates the pump; when full, it turns off the motor, preventing overfilling. This automation, combined with the inverter, makes the system efficient, reliable, and cost-effective, especially in off-grid or remote areas with limited electricity access.

In conclusion, the boost inverter effectively converts DC to AC power, ensuring the motor operates as needed.



The float switch automation enhances the system's efficiency and reliability, making it an ideal solution for solar-powered water pumping in areas with unreliable power.

output current inverter and (bottom) measure result

In conclusion, it can be stated that the design of the solar-powered automatic water pump using a single-phase boost inverter has performed effectively as anticipated.

### IV.CONCLUSION

- The solar-powered water pump system, utilizing a boost inverter, effectively increases voltage and converts DC to AC to meet the needs of the single-phase pump motor. The inverter performs well, ensuring efficient operation under varying sunlight conditions.
- The integrated float switch automates the pump operation based on water levels, preventing water wastage and optimizing pump usage. This enhances the system's efficiency and sustainability.
- The system has shown reliability and efficiency in field tests, making it a suitable solution for places of worship facing unreliable grid power. With its cost-effectiveness and lower environmental impact compared to fossil fuel-powered pumps, this system offers a sustainable alternative for accessing clean water in underserved areas.

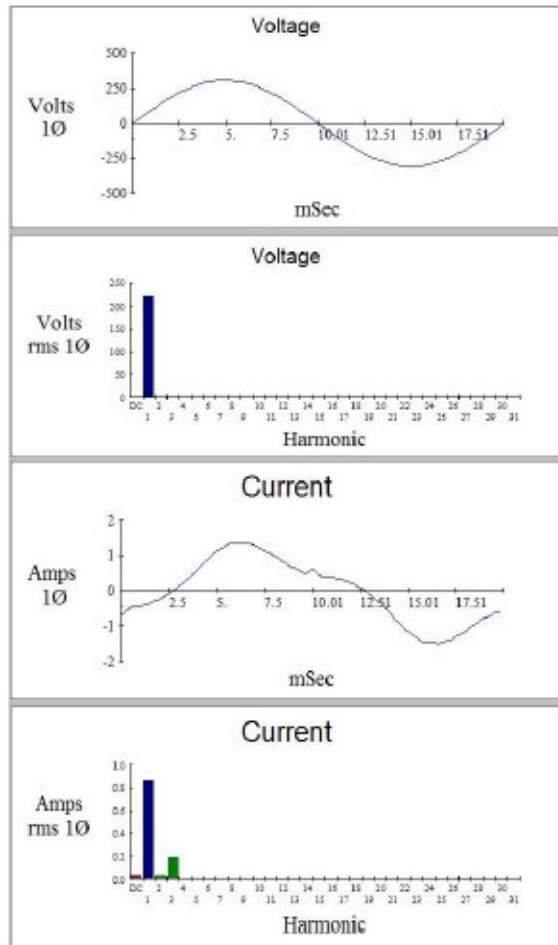

Single Phase Readings				
Summary Information			Voltage	Current
Frequency	49.97	RMS	222.0	0.89
Power		Peak	314.3	1.45
Watts	153.00	DC Offset	-0.2	-0.03
VA	197.00	Crest	1.42	1.63
Vars	116.00	THD Rms	0.51	21.81
Peak W	443.00	THD Fund	0.51	22.35
Phase	37° lag	HRMS	1.1	0.19
Total PF	0.78	KFactor		1.65
DPF	0.80			

Figure 5. Measure result inverter boost. (top) output voltage inverter, (mid)

### V.REFERENCE

[1] Nugraha, A. T., Pambudi, D. S. A., Utomo, A. P., Priyambodo, D., Hari, M. D., & Febrianto, R. RANCANG BANGUN BATTERY CHARGER PADA PEMBANGKIT LISTRIK PORTABEL ENERGI TERBARUKAN BERBASIS ARDUINO UNO R3. Deepublish, 2022.

[2] Nugraha, A. T., Widodo, H. A., Pambudi, D. S. A., Cahyono, L., Apriani, M., Utomo, A. P., Priyambodo, D., Putra, M. D. H., & Febrianto, R. "PORTABLE –

- 2WG" INOVASI TURBIN PEMBANGKIT LISTRIK PORTABLE AIR DAN ANGIN UNTUK KEBUTUHAN RUMAH TANGGA PADA PENDUDUK DAERAH ALIRAN SUNGAI. Deepublish, 2022.
- [3] Latif, A., Arfianto, A. Z., Widodo, H. A., Rahim, R., & Helmy, E. T. (2020). Motor DC PID system regulator for mini conveyor drive based-on MATLAB. *Journal of Robotics and Control (JRC)*, 1(6), 185-190.
- [4] Okasha, M., Krlev, J., & Islam, M. (2022). Design and Experimental Comparison of PID, LQR and MPC Stabilizing Controllers for Parrot Mambo Mini-Drone. *Aerospace*, 9(6), 298.
- [5] Agna, Diego Ilham Yoga, Salsabila Ika Yuniza, and Anggara Trisna Nugraha. "The Single-Phase Controlled Half Wave Rectifier with Single-Phase Generator Circuit Model to Establish Stable DC Voltage Converter Result." *International Journal of Advanced Electrical and Computer Engineering* 3.3 (2022).
- [6] Anggrila, B., & Astrid, E. (2024). Rancang Bangun DC Chopper Empat Kuadran untuk Motor DC dengan Monitoring Simulink Matlab. *MSI Transaction on Education*, 5(4), 185-196.
- [7] Nugraha, Anggara Trisna, et al. "The establishment of the Sea Turtle Conservation and Marine Pearl Educational Tourism Website in Sumbreng aims to promote ecosystem balance." *Frontiers in Community Service and Empowerment* 3.1 (2024).
- [8] Faj'riyah, Annisa Nur, Annas Singgih Setiyoko, and Anggara Trisna Nugraha. "Rancang Bangun Prototipe Proteksi Motor Terhadap Overheat Serta Monitoring Arus dan Tegangan Berbasis Arduino Uno." *Elektriase: Jurnal Sains dan Teknologi Elektro* 11.01 (2021): 20-25.
- [9] As'ad, Reza Fardiyan, Salsabila Ika Yuniza, and Anggara Trisna Nugraha. "The Effect of 3 Phase Full Wave Uncontrolled Rectifier on 3 Phase AC Motor." *International Journal of Advanced Electrical and Computer Engineering* 3.2 (2022).
- [10] Choubey, C., & Ohri, J. (2022). Tuning of LQR-PID controller to control parallel manipulator. *Neural Computing and Applications*, 34(4), 3283-3297
- [11] Yuniza, Salsabila Ika, Diego Ilham Yoga Agna, and Anggara Trisna Nugraha. "The Design of Effective Single-Phase Bridge Full Control Resistive Load Rectifying Circuit Based on MATLAB and PSIM." *International Journal of Advanced Electrical and Computer Engineering* 3.3 (2022).
- [12] Nugraha, Anggara Trisna, Oktavinna Dwi Pratiwi, and Annas Singgih Setiyoko. "SIMULASI GANGGUAN SAAT TERJADI GANGGUAN UNDERVOLTAGE DAN UNBALANCE LOAD PADA SUB-SUB DISTRIBUSI PANEL." *MEDIA ELEKTRIKA* 16.2 (2024): 162-173.
- [13] Bintari, Ayu, Urip Mudjiono, and Anggara Trisna Nugraha. "Analisa Pentahanan Netral dengan Tahan Menggunakan Sistem TN-C." *Elektriase: Jurnal Sains dan Teknologi Elektro* 12.02 (2022): 92-108.
- [14] Jamil, M. H., et al. "The existence of rice fields in Makassar City." *IOP Conference Series: Earth and Environmental Science*. Vol. 681. No. 1. IOP Publishing, 2021.
- [15] Pambudi, Dwi Sasmita Aji, et al. "Main Engine Water Cooling Failure



- Monitoring and Detection on Ships using Interface Modbus Communication." Applied Technology and Computing Science Journal 4.2 (2021): 91-101.
- [16] Dermawan, Deny, et al. "Penyearah Setengah Gelombang 3 Fasa Tak Terkendali dari Generator AC 3 Fasa." Seminar MASTER PPNS. Vol. 8. No. 1. 2023
- [17] Prastyawan, Rikat Eka, and Anggara Trisna Nugraha. "PENERAPAN TEKNOLOGI INFORMASI UNTUK PEMBELAJARAN TEST OF ENGLISH FOR INTERNATIONAL COMMUNICATION PREPARATION." Jurnal Cakrawala Maritim 5.1 (2022): 4-8.
- [18] Popov, S. A., & Krivchenkov, V. I. (2020). IDENTIFICATION OF THE TIME CONSTANT OF DC MOTOR ROTOR. PNRPU Bulletin. Electrotechnics, Informational Technologies, Control Systems, (33), 115-128.
- [19] Almunawar, Deni, et al. "Perancangan Sistem Pendukung Keputusan Mesin e-Fill Berbasis ANFIS." COMPLETE-Journal of Computer, Electronic, and Telecommunication 5.1 (2024).
- [20] Saputra, Fahmi Yahya, et al. "Efficiency Of Generator Set On Changes In Electrical Load On Fishery Vessels." MEIN: Journal of Mechanical, Electrical & Industrial Technology 1.2 (2024): 1-4.