

Analysis and Performance Evaluation of a Full-Wave Three-Phase Uncontrolled Rectifier in Driving a Single-Phase DC Motor

* Abimanyu Manap

Marine Electrical Engineering, Shipbuilding Institute of Polytechnic Surabaya, Indonesia

*Correspondence author: abimanyumanap@student.ac.id

ABSTRACT

This study examines the design and performance of a full-wave three-phase uncontrolled rectifier in driving a single-phase DC motor, focusing on its practical application in industrial settings. The three-phase DC motor is widely adopted in industry due to its operational simplicity and efficiency. However, challenges arise when converting the electrical power source, as most of the power grid in Indonesia relies on alternating current (AC). To address this issue, a rectifier circuit is essential to convert the AC input into a stable DC output using diodes, enabling compatibility with DC motor requirements. The need for robust and high-capacity DC power sources in industrial applications necessitates the use of three-phase rectifiers, which can provide higher power output compared to single-phase systems. This paper analyzes the working principles, circuit topology, and diode configuration of the three-phase uncontrolled rectifier. By integrating these components, the rectifier ensures efficient energy conversion and supports the operational demands of single-phase DC motors in industrial environments. Furthermore, this research highlights the system's performance metrics, including power efficiency, voltage regulation, and thermal characteristics, based on experimental evaluation. The findings contribute to the optimization of rectifier systems in engineering applications, emphasizing their role in enhancing the reliability and scalability of DC motor systems for industrial automation and energy systems.

Key Word: *rectifier, controlled, resource*

I. INTRODUCTION

A full-wave rectifier is a critical circuit in power electronics, designed to convert an alternating current (AC) sine wave into a direct current (DC) output. This rectification process is achieved using two sets of diode blocks arranged in parallel, allowing for the rectification of both the positive and negative cycles of the AC waveform. Compared to half-wave rectifiers, full-wave rectifiers provide a more stable DC voltage with significantly lower ripple, as the combination of both positive and negative sine wave cycles results in continuous output during the entire signal period. This characteristic makes full-wave rectifiers indispensable in applications requiring steady and reliable DC power[1].

In modern electronics, most devices operate on a 220V power supply provided by the national grid (PLN) in Indonesia, which delivers electricity in the form of AC. To adapt this alternating current for use in electronic devices, a conversion system is required. This system, commonly known as a rectifier, consists of several essential components, including transformers, diodes, and capacitors. The transformer adjusts the voltage level either stepping it up or down according to the circuit's requirements[2][3]. Diodes play a dual role by rectifying the electrical signal to DC and protecting the circuit from reverse current. Capacitors are incorporated to filter and stabilize the rectified signal, ensuring smooth operation by reducing ripple and providing temporary energy storage.

The significance of full-wave rectifiers extends to their application in industrial systems, particularly in powering DC motors. As the industry increasingly relies on automation and motor-driven systems, the demand for efficient and reliable DC power sources grows. This paper explores the performance and operational advantages of a full-wave three-phase uncontrolled rectifier in driving single-phase DC motors, emphasizing its ability to address industrial challenges such as power stability and scalability. The analysis aims to provide engineers and researchers with valuable insights into the rectifier's design, functionality, and contributions to advancing power electronics systems in industrial applications.

II.METHODOLOGY

1. Circuit of 3 Phase Rectifier

Power rectifier circuits can be categorized based on three primary criteria: the input voltage source, the resulting output waveform, and the type of load applied to the circuit[4]. From the perspective of the input voltage source, rectifier circuits are divided into two main types: (1) Power Rectifier Circuits utilizing a Single-Phase AC Voltage Source and (2) Power Rectifier Circuits utilizing a Three-Phase AC Voltage Source. Regarding the waveform of the output, these circuits are further classified into (1) Half-Wave Rectifier Circuits and (2) Full-Wave Rectifier Circuits. Finally, based on the type of load connected to the circuit, rectifiers can be distinguished as (1) Rectifiers with Resistive (R) Loads and (2) Rectifiers with Resistive-Inductive (RL) Loads, as described by Ali (2018)[2].

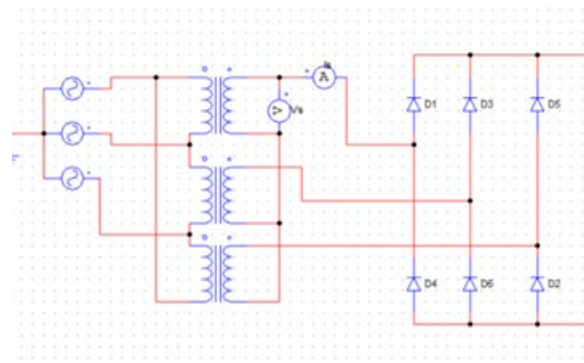

Figure 1: Three-Phase Rectifier Circuit

A three-phase rectifier circuit is designed to convert three-phase AC power into a DC output and serves as a critical component in industrial applications[5]. This type of circuit is widely implemented in various industrial systems, either as a stand-alone unit or as part of more sophisticated electrical systems. Compared to single-phase rectifiers, three-phase rectifier circuits offer significant advantages, including smoother and more stable DC output. The improved waveform quality minimizes ripple, which in turn reduces the size and capacity requirements for filter capacitors. This feature makes three-phase rectifiers particularly efficient and cost-effective for high-power applications, as highlighted by Ali (2018)[2].

2.Diode

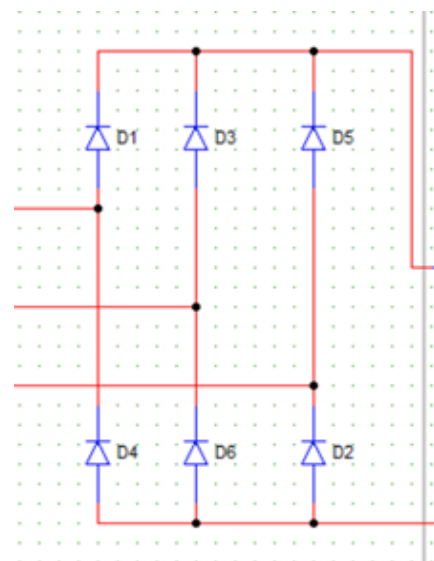

Figure 2. Diode

Diodes play a pivotal role in rectifier circuits, serving as the primary component responsible for converting alternating current (AC) signals into direct current (DC) signals. As a type of active semiconductor device, diodes are highly valued for their simplicity, reliability, and versatility in electronic circuit design. The widespread application of diodes has led to the development of various rectifier configurations, including the Half-Wave Rectifier, Full-Wave Rectifier, Clipper Circuit, Clamper Circuit, and Voltage Multiplier [6]. Each configuration offers unique functionalities tailored to specific industrial and engineering needs, demonstrating the versatility and indispensability of diodes in modern technology. These configurations are essential in various applications, including power supply design, signal processing, and voltage regulation, showcasing the fundamental role that diodes play in electronic systems.

Diodes are constructed from semiconductor materials, primarily silicon or germanium, and are characterized by their unidirectional current flow. This functionality stems from their P-N junction structure, where one side consists of P-type semiconductor material and the other of N-type. This configuration allows current to flow only from the P-side (anode) to the N-side (cathode), effectively blocking reverse current. Such properties make diodes essential for rectification processes, voltage regulation, and signal shaping. The evolution of diodes from their initial invention has also led to the creation of specialized derivatives, such as Zener diodes for voltage stabilization and Schottky diodes for high-speed switching, further expanding their role in advanced engineering systems [8]. These innovations in diode technology have significantly enhanced the performance and efficiency of modern electronic circuits, especially in high-power and high-frequency applications, where reliable and rapid rectification is crucial.

Additionally, the use of diodes extends beyond basic rectification, playing a key role in power electronics systems such as power converters, motor controllers, and renewable energy applications. Diodes help ensure smooth and efficient energy conversion, making them indispensable in both traditional and emerging technologies. As the demand for more efficient, compact, and reliable electronic systems continues to grow, the role of diodes in meeting these needs becomes even more critical. Their ability to withstand high voltages, handle large currents, and operate in harsh conditions makes them a cornerstone of modern electrical and electronic devices.

3.DC Motor 1 Phase

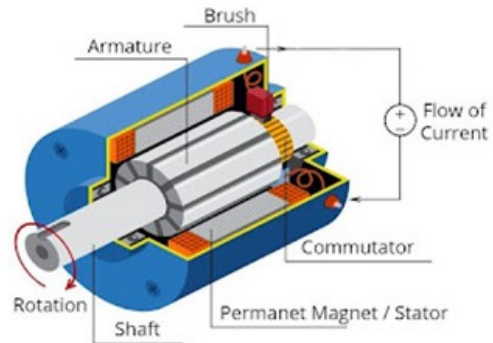

Figure 3. DC Motor 1 Phase

Electric motors serve as critical components in converting electrical energy into mechanical energy, supporting a wide range of applications across industries and households. This mechanical energy drives key systems such as pump impellers, fans, blowers, compressors, and material handling equipment. Due to their versatility and efficiency, electric motors are often regarded as the "workhorses" of industry, accounting for approximately 70% of the total industrial electrical energy consumption. In domestic applications, devices like mixers, electric drills, and wind fans rely on electric motors for their functionality. The efficiency and reliability of these motors play a pivotal role in the smooth operation of both residential and industrial systems, underlining their broad

significance in engineering design and application.

empirical data that reflects how the rectifier impacts motor operation, voltage regulation, and overall system performance.

4. Transformator

Transformers are categorized based on their construction and the application they serve. Core-type transformers are commonly used for applications that require high voltage ratings, such as in power transmission lines[9]. The simple design of core-type transformers makes them suitable for large-scale energy distribution, where voltage needs to be either stepped up or stepped down for efficient transmission over long distances. On the other hand, shell-type transformers are preferred in applications that require better shielding and lower electromagnetic interference. Their design allows them to be more compact and efficient in industrial settings where space constraints and safety considerations are critical. The versatility of transformers makes them vital in a variety of engineering fields, particularly in the integration of electrical power systems for industries and households. With innovations in transformer technology, their performance continues to improve, making them a cornerstone of modern power management and distribution systems [7].

5. Metode

In this research, the scientific approach is employed to gather and analyze data. A quantitative research method is applied to quantify the performance of a full-wave three-phase uncontrolled rectifier. This method is particularly effective in evaluating the rectifier's behavior and efficiency when integrated into a single-phase DC motor system[10]. The study primarily focuses on simulations conducted using PSIM software, which provides an accurate representation of the rectifier circuit's performance under various operational conditions. By simulating the system, the research aims to obtain

1. Simulation On Circuits

To understand the operational characteristics of the rectifier and determine its output, it is essential to conduct a series of simulations that accurately replicate real-world conditions. These simulations allow for a detailed analysis of the rectifier's behavior under various operating conditions and provide insights into its performance in different scenarios. PSIM software, known for its high accuracy and reliability in power electronics simulation, is utilized to model the rectifier circuit in this study. PSIM's sophisticated capabilities in simulating power systems make it an ideal tool for evaluating complex circuits, such as rectifiers, and assessing how they interact with other components within the system.

The simulation is specifically designed to observe the conversion process from alternating current (AC) to direct current (DC), which is the primary function of the rectifier. By modeling this conversion process, the simulation can accurately capture key parameters such as voltage ripple, current flow, and power losses that occur during rectification. Additionally, the software provides the ability to test different circuit configurations and component values, allowing for a thorough evaluation of the rectifier's efficiency and performance in various conditions. This approach helps to identify any potential inefficiencies in the system and provides opportunities for optimization.

Furthermore, the simulation is also aimed at evaluating the rectifier's efficiency in driving a single-phase DC motor. The motor's behavior under different voltage conditions, such as varying load and supply voltage, can be simulated to assess how well the rectifier maintains a stable and reliable DC output for motor operation. This aspect of the simulation is crucial because the performance of the motor, including its speed, torque, and overall efficiency, is

directly influenced by the quality and stability of the DC power supplied by the rectifier. Through these simulations, it is possible to gain valuable insights into the system's overall efficiency, motor control characteristics, and potential areas for improvement in both the rectifier and motor performance.

direction. The diodes are activated in a sequence that efficiently smooths out the ripples in the current, ensuring a relatively stable DC output that is suitable for driving the motor.

Once the AC voltage has been converted into DC by the rectifiers, the current flows into the DC motor, where it is used to generate rotational motion. The efficiency of the rectifier circuit plays a significant role in determining how effectively the motor operates, as any irregularities in the DC supply, such as excessive ripple or voltage fluctuations, can negatively impact the motor's performance. By observing the motor's behavior under different voltage levels and rectifier conditions, this experiment provides valuable insights into the relationship between the rectified voltage and the motor's operational characteristics, such as speed, torque, and efficiency. Additionally, the experiment helps in understanding the impact of various transformer outputs and rectifier configurations on the overall system's performance.

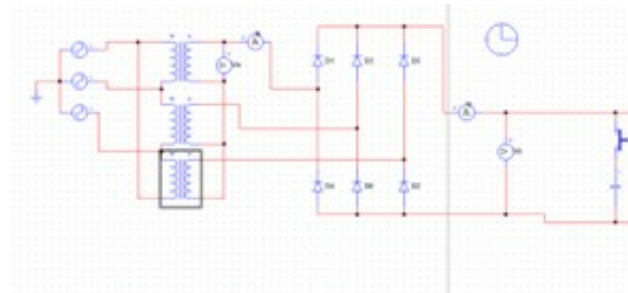

Figure 4. Simulation Circuit

III.RESULT & DISCUSION

1.Result

In this circuit experiment, the output voltage of a three-phase transformer is initially set to 380V, which serves as the primary voltage source for the system. This voltage is then stepped down to three different levels—30V, 45V, and 60V—using appropriate voltage reduction techniques. The stepping down of voltage is a critical process, as it ensures that the DC motor receives the correct input voltage for operation, depending on the specific requirements of the system. These different voltage levels allow for a comprehensive analysis of how the motor responds to varying input voltages, helping to evaluate its performance under different load and voltage conditions.

After the voltage is stepped down, it is processed by six rectifier diodes arranged in a configuration designed to convert the alternating current (AC) into direct current (DC). The rectification process is essential because the DC motor requires a steady, unidirectional current for efficient operation, and the diodes ensure this conversion by allowing current to flow in only one

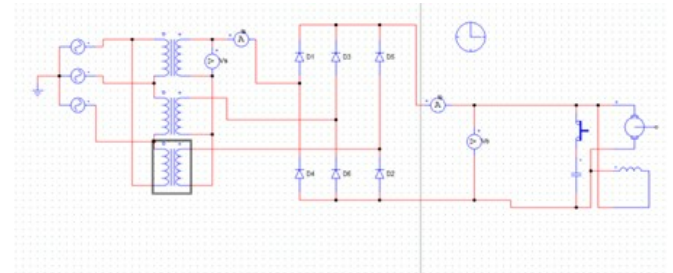

Figure 5. DC Motor 1 Phase

From the three experiments without a load, using three different voltages of 30V, 45V, and 60V, the output produced is:

Table 1. Simulation result

$V_O(rms)$ L-N	$V_o(dc)$)	$I_o(dc)$	$V_O(rms)$	$I_o(rms)$
30	10.38	8.15e-04	13.10	8.77e-04
45	69.20	5.53e-04	87.37	5.84e-04
60	51.90	4.07e-04	65.52	3.47e-04

Table 2. Test result

$V_{O(rms)}$ L-N	$V_{o(dc)}$	$V_{O(rms)}$	$I_s(rms)$
30	49.62	49.662	6.94e-04
45	74.43	74.493	4.62e-04
60	99.24	99.324	3.47e-04

By calculating $V_{O(dc)}$ and $V_{O(rms)}$ as follows
No-load circuit calculation

- $V_{s(max)L-N} = 30 \text{ Volt}$

$$V_{o(dc)} = 1.654 \times V_{s(max)L-N}$$

$$V_{o(rms)} = 1.6554 \times V_{s(max)L-N}$$

$$V_{o(dc)} = 1.654 \times 30 = 49.62 \text{ V}$$

$$V_{o(rms)} = 1.6554 \times 30 = 49.662 \text{ V}$$

- $V_{s(max)L-N} = 45 \text{ Volt}$

$$V_{o(dc)} = 1.654 \times V_{s(max)L-N}$$

$$V_{o(rms)} = 1.6554 \times V_{s(max)L-N}$$

$$V_{o(dc)} = 1.654 \times 45 = 74.43 \text{ V}$$

$$V_{o(rms)} = 1.6554 \times 45 = 74.493 \text{ V}$$

- $V_{s(max)L-N} = 60 \text{ Volt}$

$$V_{o(dc)} = 1.654 \times V_{s(max)L-N}$$

$$V_{o(rms)} = 1.6554 \times V_{s(max)L-N}$$

$$V_{o(dc)} = 1.654 \times 60 = 99.24 \text{ V}$$

$$V_{o(rms)} = 1.6554 \times 60 = 99.324 \text{ V}$$

Based on the data and calculations above, when the voltage is reduced to 30V, 45V, and 60V, there will be a decrease in current, which in turn will cause the RPM of the DC motor to decrease.

- Simulation results at a voltage of 30 v

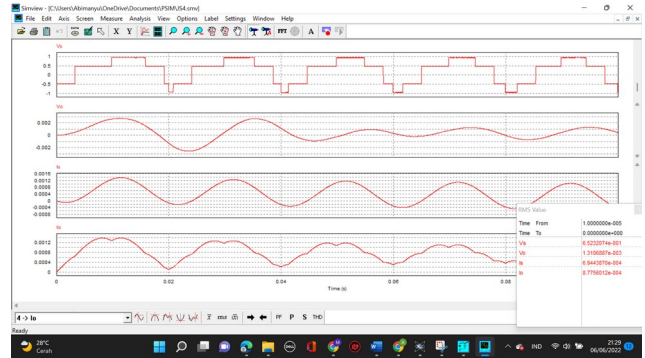

Figure 6. rms value and waveform of experiment 1 with a 30 v

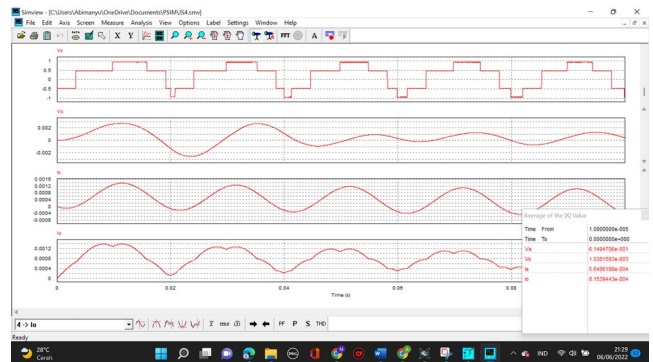

Figure 7. average value and waveform of experimental rectifier 1 with a 30 V

- Simulation results at a voltage of 45 v

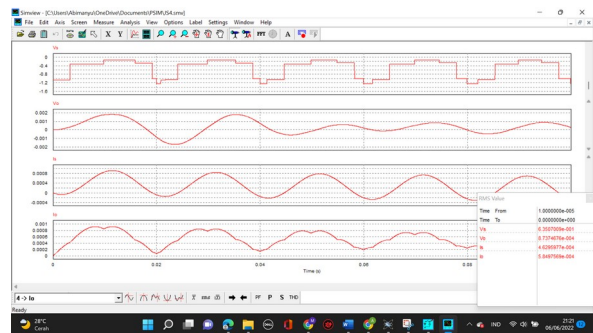

Figure 8. average value and waveform of experimental rectifier 2 with a 45 v

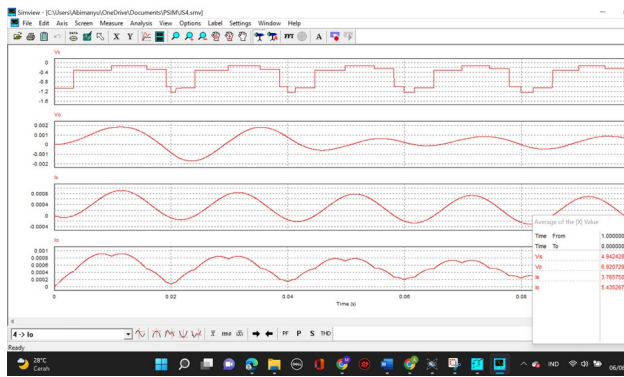

Figure 9. average value and waveform of experimental rectifier 2 with a 45 v

- Simulation results at a voltage of 60 v

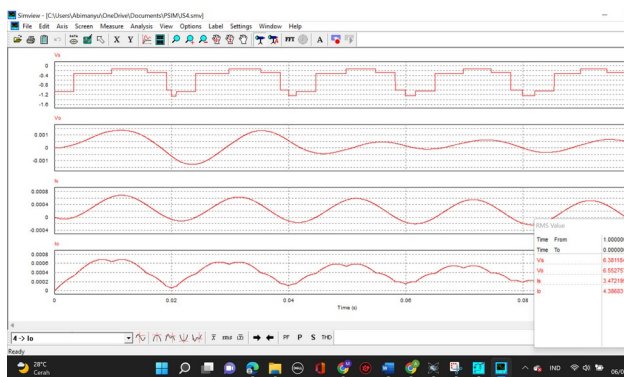

Figure 10. average value and waveform of experimental rectifier 3 with a 60 v

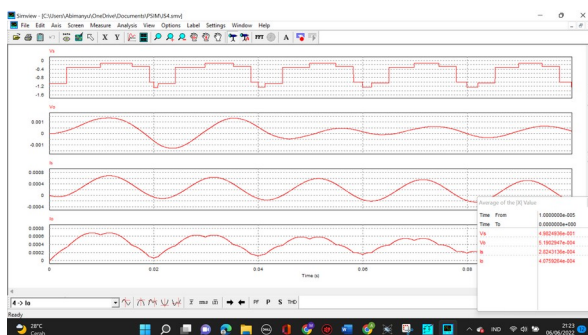

Figure 11. average value and waveform of experimental rectifier 3 with A 60 v

IV.CONCLUSION

- The simulation results indicate that the three-phase uncontrolled rectifier circuit successfully supplies voltage to a single-phase DC motor in three different test scenarios with

varying voltage levels (30V, 45V, and 60V). These experiments confirm the rectifier's ability to provide stable and consistent output suitable for driving the motor, with the system demonstrating reliable functionality under different operational conditions.

- As the input voltage decreases, there is a noticeable reduction in the current flowing to the DC motor. This decline in current directly affects the motor's performance, leading to a decrease in the rotational speed (RPM). This observation highlights the critical dependency of motor performance on the rectifier's voltage output and provides insight into the behavior of the system under different electrical load conditions.
- The analysis reveals a clear correlation between the applied voltage and the motor's rotational speed. Higher applied voltage results in increased current flow, which in turn generates higher motor speeds. This finding underscores the importance of voltage regulation in optimizing motor performance, particularly in applications where precise speed control is essential. The study's outcomes provide a basis for further research on improving rectifier circuit designs for more efficient motor control in industrial settings.

V.REFERENCE

[1] Rahman, Farhan Wahyu Nur, et al. "ASSESSING THE MARKETING APPROACH OF PT PAL INDONESIA COMPANY THROUGH A SWOT ANALYSIS." *Jurnal Cakrawala Maritim* 6.1 (2023): 20-24.

[2] Nugraha, A. T., Pambudi, D. S. A., Utomo, A. P., Priyambodo, D., Hari, M. D., &

- Febrianto, R. RANCANG BANGUN BATTERY CHARGER PADA PEMBANGKIT LISTRIK PORTABEL ENERGI TERBARUKAN BERBASIS ARDUINO UNO R3. Deepublish, 2022.
- [3] Handandi, Zukhruf Zidane, et al. "HOW THE PERFORMANCE OF A DC MOTOR SYSTEM IS IMPACTED BY NOISE." *Jurnal Teknologi Maritim* 6.1 (2023): 11-16.
- [4] Alzahrani, A. (2023). Experimental Investigation of Controlled and Uncontrolled Rectifiers for Low-Power Wind Turbines. *Applied Sciences*, 13(7), 4120.
- [5] Shneen, S. W., Ahmedhamdi, R. T., & Al-Ghezi, M. K. (2022). A-review of Simulink for single-phase rectifier. *Int J Adv Appl Sci* ISSN, 2252(8814), 8814.
- [6] Nugraha, Anggara Trisna, et al. "ANALISIS POSTUR TUBUH PEKERJA PADA AKTIVITAS PROYEK KONSTRUKSI DENGAN METODE RULA (RAPID UPPER LIMB ASSESMENT) DI CV. BASANI." *Jurnal Cakrawala Maritim* 4.2 (2021): 9-21.
- [7] Magriza, Rania Yasmin, et al. "Design and Implementation of Water Quality Control in Catfish Farming Using Fuzzy Logic Method with IoT-Based Monitoring System." *Jurnal Teknologi Maritim* 4.1 (2021): 13-18
- [8] Mu'in, Misbakhul, et al. "ANALISIS ALIRAN DAYA DAN CAPASITOR PLACEMENT PADA SISTEM KELISTRIKAN PT BLAMBANGAN BAHARI SHIPYARD DENGAN SOFTWARE ETAP." *Jurnal 7 Samudra* 8.1 (2023).
- [9] Amrullah, Muhammad'Ubaid, et al. "RANCANG BANGUN MONITORING KUALITAS AIR TAMBAK UDANG VANAME DENGAN KONTROL PADDLE WHEEL BERBASIS MIKROKONTROLLER." *Jurnal 7 Samudra* 8.2 (2023): 117-122.
- [10] Pangestu, Nanda Dwi, et al. "PERANCANGAN SMART PROTECTION PADA MOTOR KINCIR AERATOR TAMBAK UDANG MENGGUNAKAN LOGIKA FUZZY." *Jurnal 7 Samudra* 9.1 (2024): 1-8.
- [11] Hidayana, Elmi, et al. "UTILIZATION OF BAGASSE WASTE FOR BIO-OIL EXTRACTION FROM SUGARCANE JUICE VENDORS IN BANYUWANGI REGENCY." *Jurnal Cakrawala Maritim* 7.1 (2024): 43-51.
- [12] Nugraha, Anggara Trisna. RANCANG BANGUN TEKNOLOGI PEMURNI AIR. Deepublish, 2022
- [13] Apriani, Mirna, et al. "Coastal Community Empowerment Recovery of cockle shell waste into eco-friendly artificial reefs in Mutiara Beach Trenggalek Indonesia." *Frontiers in Community Service and Empowerment* 1.4 (2022).
- [14] Du, Q., Fang, Z., Gao, L., Li, Q., Li, F., & Meng, F. (2023). Open-Phase Fault Research on the Parallel-Connected 40-Pulse Rectifier With Multioutput Auto-Connected Phase-Shifting Transformer. *IEEE Journal of Emerging and Selected Topics in Power Electronics*, 11(4), 4108-4118.
- [15] Nugraha, Anggara Trisna, et al. "Comparison of Insulated Switch Gear with Desiccant Addition to SF6 Gas Quality System at Waru Substation." *JEEEMCS (Journal of Electrical Engineering, Mechatronic and Computer Science)* 6.2 (2023): 77-86.
- [16] Prastyawan, Rikat Eka, and Anggara Trisna Nugraha. "PENERAPAN TEKNOLOGI INFORMASI UNTUK PEMBELAJARAN TEST OF ENGLISH FOR INTERNATIONAL COMMUNICATION PREPARATION." *Jurnal Cakrawala Maritim* 5.1 (2022): 4-8.
- [17] Tawfeeq, O. T., & Alattar, M. S. (2023, December). Filter design for harmonics reduction in multi phases system rectifier driving dc motor. In 2023 International Conference on Electrical, Communication and Computer Engineering (ICECCE) (pp. 1-4). IEEE.
- [18] Ainudin, Fortunaviaza Habib, Muhammad Bilhaq Ashlah, and Anggara Trisna Nugraha. "Pengontrol Kecepatan Respon Motor dengan Pid dan Lqr." *Seminar MASTER PPNS*. Vol. 7. No. 1. 2022.

- [19] Sasongko, Adhy, et al. "Estimation of the thrust coefficient of a Quadcopter Propeller using Computational Fluid Dynamics."
- [20] Nugraha, Anggara Trisna, et al. "ANALISIS POSTUR TUBUH PEKERJA PADA AKTIVITAS PROYEK KONSTRUKSI DENGAN METODE RULA (RAPID UPPER LIMB ASSESMENT) DI CV. BASANI." *Jurnal Cakrawala Maritim* 4.2 (2021): 9-21.