

## Impact of Half-Wave Uncontrolled Rectification on DC Motor Performance

\*Mochammad Akbar Gibran<sup>1</sup>, Mukhammad Jamaludin<sup>2</sup>

<sup>1</sup>Marine Electrical Engineering, Shipbuilding Institute of Polytechnic Surabaya

<sup>2</sup>Bio-Industrial Mechatronics Engineering, National Chung Hsing University, taiwan  
[akbargibran25@student.ppns.ac.id](mailto:akbargibran25@student.ppns.ac.id)

### Abstract

Half-wave uncontrolled rectifiers play a pivotal role in converting sinusoidal alternating current (AC) signals into direct current (DC) voltage. This study examines the impact of a single-phase half-wave uncontrolled rectifier on the performance dynamics of a DC motor, particularly focusing on the relationship between rotational speed (RPM) and time. Utilizing a diode as both a rectifying element and a circuit switch, the rectifier introduces significant variations in the motor's operational characteristics. Experimental results demonstrate that the RPM of the DC motor exhibits a proportional increase with time under specific rectification conditions, shedding light on the transient behavior and stability of the system. This research contributes to the understanding of how rectification methods influence motor performance, offering valuable insights for optimizing motor control in industrial and engineering applications. The findings also pave the way for future advancements in efficient rectifier designs and motor performance analysis.

Keywords: Half-wave uncontrolled, RPM, Rectifiers

### 1. Introduction

The rapid advancement of industrial development parallels technological progress, particularly in power supply systems such as rectifiers, which convert alternating current (AC) into direct current (DC) (Nugraha & Eviningsih, 2022). In modern industrial applications, power equipment requires continuous control to achieve the desired performance of electrical systems and machinery (ÖZÇELİK & AYCAN, 2022). The ability to maintain optimal performance ensures both operational efficiency and reliability in various industrial processes.

This study focuses on the use of a single-phase half-wave uncontrolled rectifier circuit to analyze its impact on the performance of a DC motor under varying load conditions (Salamena, 2020). A rectifier circuit is fundamentally a system that converts sinusoidal AC input into a series of unidirectional DC pulses, as noted by (Alzahrani, 2023). The core component of this circuit is the diode, a semiconductor device that functions as a current rectifier, a safeguard against voltage surges, and a block for reverse currents. The output voltage of a half-wave rectifier consists solely of the positive portion of the AC waveform, leaving the negative portion suppressed.

Structurally, a half-wave rectifier circuit typically comprises a transformer, diode, and a capacitor or condenser, each playing a pivotal role in its operation (Nugraha & Eviningsih, 2022). The transformer acts as a filter by momentarily storing charge, while the diode ensures the unidirectional flow of current and voltage rectification. The capacitor contributes by smoothing the pulsating DC output, enhancing its usability for electrical and electronic applications.

Electric motors, the primary focus of this study, can be broadly categorized into AC and DC motors (Nugraha et al., 2023). DC motors possess distinctive characteristics compared to their AC counterparts, including their ability to function as AC generators under certain conditions. Their versatility is evident in applications ranging from powering children's toys to driving heavy industrial equipment like cranes (Zhang et al., 2022). The primary role of DC motors is to convert electrical energy into mechanical energy, making them indispensable in numerous engineering systems.

In this research, we investigate the influence of the output current characteristics of a single-phase half-wave uncontrolled rectifier on the operational performance of a DC motor (Bidadfar et al., 2020). The study aims to elucidate the relationship between rectifier output and motor dynamics, contributing valuable insights into the design and optimization of power supply systems in engineering applications.

## 2. Material and methods

### 2.1. Diode

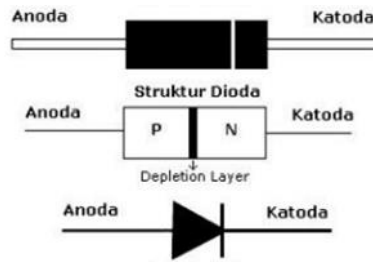

Figure 1. Diode Symbol

A diode is a fundamental semiconductor component with two terminals: the anode and the cathode (Li & Xu, 2020). As illustrated in Figure 1, the anode is located on the left side of the diode, while the cathode occupies the right side. The behavior of the diode is influenced by the direction of current flow through it, which is a key factor in its application within rectification circuits.

- Forward Bias in Diodes

When the P-region of the diode is connected to the positive terminal of a DC voltage source, and the N-region is connected to the negative terminal, the diode operates in a forward-biased condition (As'ad et al., 2022). In this state, the applied voltage reduces the barrier potential, allowing a significant current to flow through the diode. This forward-bias current is instrumental in enabling the rectification process by permitting current flow in one direction while blocking it in the opposite direction (Nangka et al., 2019).

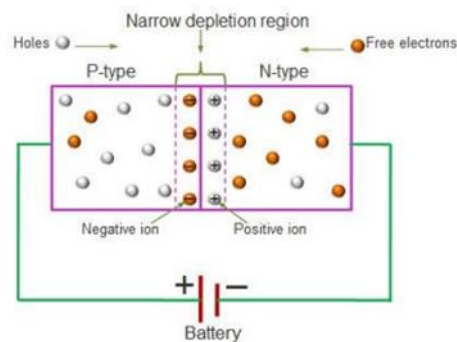

Figure 2. Forward bias

Figure 2 illustrates the forward bias condition, demonstrating how the reduction in the potential barrier facilitates the flow of charge carriers, ensuring effective current rectification.

- Reverse Bias in Diodes

Conversely, when the N-region of the diode is connected to the positive terminal of the DC voltage source, and the P-region is connected to the negative terminal, the diode operates in a reverse-biased condition. In this scenario, the external voltage increases the width of the depletion layer, effectively preventing the flow of current under normal conditions.

As the reverse bias voltage increases, the depletion region continues to expand, as described by Nangka et al. (2019). This phenomenon persists until the potential difference across the diode matches the applied voltage, at which point the depletion layer reaches its maximum width, and current flow ceases. This characteristic is critical for the diode's role in blocking reverse current in rectifier circuits.

The forward and reverse bias characteristics of diodes are pivotal in their application within single-phase half-wave rectification circuits. In such circuits, the diode alternates between forward bias (allowing current flow during the positive half-cycle of the AC input) and reverse bias (blocking current during the negative half-cycle). This operation converts the sinusoidal AC waveform into a pulsating DC output, which is a key process in powering DC motors and other electronic systems.

Understanding these fundamental properties of diodes is essential for optimizing their application in engineering fields, particularly in power electronics and motor control systems. By analyzing their behavior under varying bias conditions, researchers can design more efficient rectification circuits tailored to specific industrial and technological requirements.

## 2.2. Transformer

A transformer is a static electromagnetic device designed to transfer electrical energy between circuits through the principle of electromagnetic induction (Gawrylczyk & Banaszak, 2021). Operating at the same frequency, it facilitates the transformation of voltage and current levels based on a specified transformation ratio. Transformers are integral to numerous electrical applications, including power conditioning and rectification, particularly in single-phase half-wave rectification systems (Abbasi et al., 2021).

The working principle of a transformer is grounded in Lorentz's law and Faraday's law of electromagnetic induction. When an alternating current (AC) voltage source is connected to the primary winding of the transformer, a current flows through the primary coil. This current generates a time-varying magnetic flux in the transformer's iron core.

The generated magnetic flux is linked to the secondary winding, inducing a voltage due to electromagnetic induction (Moradnouri et al., 2020). This induced voltage enables the transfer of energy from the primary to the secondary circuit. The efficiency and stability of this energy transfer depend on the design parameters, such as the core material, winding configuration, and operating frequency.

When a sinusoidal AC voltage is applied to the primary winding, it produces a magnetizing current ( $I\mu$ ) in the coil (Li et al., 2021). This current generates a magnetic flux ( $\phi$ ) in the transformer's core. The flux induces counter electromotive forces (EMF) in both the primary ( $E_1$ ) and secondary ( $E_2$ ) windings. These counter EMFs play a crucial role in regulating the energy transfer between the windings.

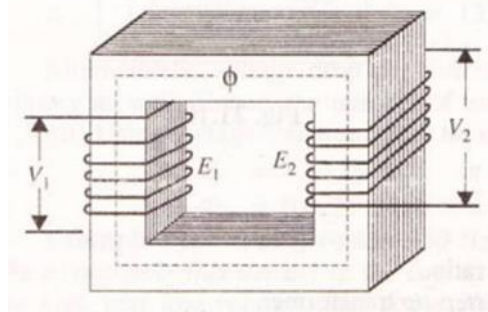

Figure 3. Transformer

Figure 3 demonstrates the magnetic flux generation and the resulting induced EMFs within the transformer. The interplay of these electromagnetic forces ensures that the output voltage is consistent with the transformation ratio and suitable for subsequent rectification processes.

In the context of single-phase half-wave uncontrolled rectification, the transformer functions as a critical component for voltage conditioning. The primary winding receives the sinusoidal AC input, while the secondary delivers an adjusted voltage to the rectifier circuit (Jabari et al., 2024). This adjustment ensures that the diode in the rectifier operates within its optimal parameters, effectively converting the AC waveform into a pulsating DC output.

The use of a transformer in such systems offers several advantages:

- Voltage Adaptation: It allows the rectification circuit to operate at a voltage level appropriate for the connected DC load, such as a DC motor.
- Isolation: Transformers provide electrical isolation between the AC source and the rectifier, enhancing system safety.
- Magnetic Efficiency: By concentrating the magnetic flux within its core, the transformer minimizes energy losses, which is essential for efficient rectification.

## 2.3. Uncontrolled Rectifier

A power rectifier is a fundamental component in power electronics, designed to convert an alternating current (AC) input voltage, typically sinusoidal, into a direct current (DC) voltage with a steady polarity (Agha et al., 2022). This process is critical in applications requiring a stable DC power source from an AC supply, such as in motor control systems, renewable energy integration, and various industrial applications (Nangka, 2019).

#### 2.4. Rectifier Single Phase Half Wave Resistive Load

A half-wave single-phase uncontrolled rectifier utilizes a single diode to rectify an alternating current (AC) input. The rectifier's output is a positive waveform derived from one half of the sinusoidal AC wave.

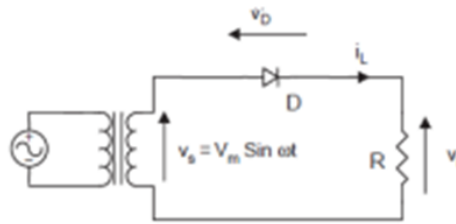

Figure 4. Half-wave single-phase uncontrolled rectifier with resistive load (R)

When the AC voltage source provides a positive current, the diode becomes forward-biased, allowing current to flow from the source to the load. For a resistive load, which has a unity power factor ( $\cos \phi = 1$ ), the voltage and current waveforms are in phase, as noted by Nangka (2019).

During operation, the rectifier generates an output voltage ( $V_L$ ) that corresponds to the positive half-cycle of the input sinusoidal waveform. In the negative half-cycle, as the diode blocks the current, no voltage is supplied to the load, resulting in an output voltage of zero. This rapid switching of the diode between conduction and blocking states depends on the frequency of the AC source.

In this configuration, the diode serves dual roles: acting as a switch and converting the alternating voltage into a unidirectional (direct) voltage. The rectified output voltage ( $V_L$ ) includes two main components:

1. Average direct voltage ( $V_{dc}$ )
2. Effective direct voltage (root mean square,  $V_L \text{ rms}$ )

The respective values of these components depend on the rectifier's operation and input waveform.

#### 2.5. Single phase half wave uncontrolled rectifier RL Load

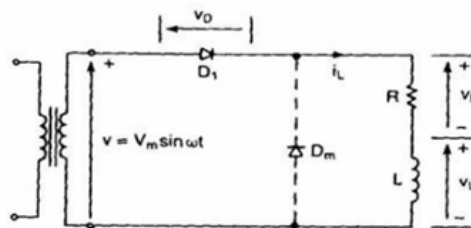

Figure 5. Half-wave single-phase uncontrolled rectifier circuit with commutating diode

The working principle of a single-phase half-wave uncontrolled rectifier with an RL load is similar to that of a single-phase half-wave rectifier with a purely resistive load (Ma'arif & Setiawan, 2021). However, the inductive component ( $L$ ) introduces additional behavior due to its ability to store energy in the form of magnetic fields.

##### Operating Principle

- During the positive half-cycle, the diode becomes forward-biased and conducts current. The inductor stores energy while current flows through the circuit.
- The inductor's energy storage extends the conduction period of the diode beyond the standard half-cycle ( $\pi$  radians), lasting until a certain angle  $\beta$ . This results in a diode conduction angle of  $\pi + \theta$ .
- In the subsequent negative half-cycle, the diode turns off as it becomes reverse-biased, halting the current flow.

#### 2.6. DC Motor

A DC motor is a fundamental electromechanical device designed to transform electrical energy into mechanical energy (Jabari et al., 2024). This transformation enables DC motors to power a wide range of applications, from industrial machinery to consumer electronics. The efficient operation of a DC motor relies on its connection to a stable DC voltage source, which supplies the energy required to generate mechanical motion.

In a DC motor, the rotation is caused by the interaction between the armature coils and the field coils. These two sets of coils work together to generate motion when an electric current flows through them (Ma'arif & Setiawan, 2021). The operating principle of the DC motor is based on Lorentz's experiments, which state that

when a current-carrying conductor is placed in a magnetic field, it will experience a force (Zhang & Gao, 2022). This force, known as the Lorentz force, is the driving factor behind the motor's rotation.

The Lorentz force can be explained through the relationship between the electric current, the magnetic field, and the resulting force on the conductor (Sami et al., 2021). When current flows through the armature coils, which are positioned within the magnetic field created by the field coils, a force is generated that acts perpendicular to both the current and the magnetic field. This force causes the armature to rotate, and through this rotational movement, the DC motor is able to convert electrical energy into mechanical energy (Khalifa et al., 2021).

**3. Results and discussion**

**3.1. Result**

In a DC motor, the rotational speed (rpm) increases progressively over time as the motor operates. However, this increase in speed is not instantaneous; it exhibits a delay or lag that is approximately equal to half the period of the input voltage source. This lag is a characteristic of the motor's response to the pulsating direct current (DC) supplied by the half-wave uncontrolled rectifier. The delayed rise in rpm is due to the time it takes for the rectified voltage to build up sufficient energy to accelerate the motor.

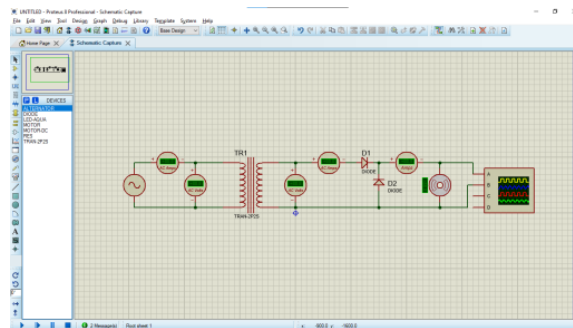

**Figure 6.** Circuit before simulation

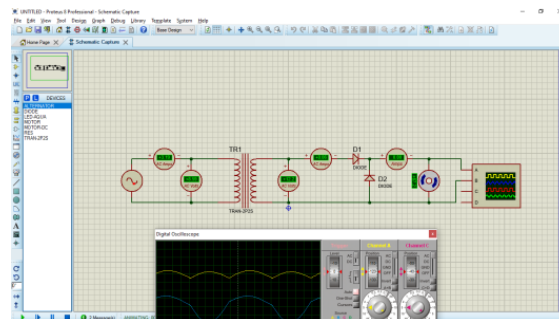

**Figure 6.** Sequence after simulated

**Table 1.** Simulation result

Second (s)	Rpm
1-10	0-75.1
10-20	75.1-130
20-30	130-171
30-40	171-205
40-50	205-228
50-60	228-243

The observed behavior of the DC motor in this study can be attributed to the characteristics of the rectifier circuit, which alternates between blocking and allowing the flow of electric current. As explained in the theory, the diode in the circuit functions as a switch, alternately permitting and blocking the flow of current. This is fundamental in creating the rectified output required to power the DC motor. The experimental setup used a single-phase half-wave rectifier circuit with an RL load, where the motor's electrical characteristics are influenced by both its resistive and inductive components.

An uncontrolled rectifier is an electronic circuit that converts an alternating current (AC) input into direct current (DC). Specifically, a half-wave rectifier is used in this study, where the rectification process is achieved without any control over the current. The rectifier's output, which is sinusoidal in form, is then converted to a constant DC voltage. The power rectifier is responsible for ensuring the voltage conversion, with the circuit capable of working with either a single-phase or three-phase alternating current (AC) supply.

In engineering applications, particularly in DC motor systems, the performance of the motor is directly impacted by the type of rectifier used. The half-wave uncontrolled rectifier introduces significant ripple in the DC output, leading to variable motor performance that can be observed as fluctuations in motor speed and torque. This uncontrolled rectification method is often used in systems where precise control is less critical, but it still requires careful consideration of its impact on motor operation.

#### **4. Conclusion**

The performance of a DC motor coupled with a single-phase half-wave uncontrolled rectifier exhibits an increasing rotational speed (rpm) over time, albeit with a lag in the rate of speed increase. This delay is attributed to the pulsating nature of the direct current (DC) provided by the half-wave rectifier, which converts alternating current (AC) from the input source. The diode in this configuration functions as a key component in rectifying the AC signal, transforming it into a unidirectional flow of current suitable for powering the DC motor.

The rectified output from the half-wave uncontrolled rectifier in a circuit with a resistive load (R) results in a positive half-sine wave, which lacks a negative valley. This output waveform closely resembles that of a single-phase half-wave rectifier, with the crucial distinction being that the amplitude of the waveform does not touch the zero-point. This deviation occurs due to the phase angle differences in the AC input, which impact the magnitude and continuity of the rectified voltage.

These findings highlight the critical relationship between rectifier characteristics and motor performance, underscoring the importance of understanding how fluctuations in the rectified waveform affect the motor's speed and torque.

#### **Credit authorship contribution statement**

**Author Name:** Conceptualization, Writing – review & editing. **Author Name:** Supervision, Writing – review & editing. **Author Name:** Conceptualization, Supervision, Writing – review & editing.

#### **References**

- Nugraha, Anggara Trisna, and Rachma Prilian Eviningsih. *Konsep Dasar Elektronika Daya*. Deepublish, 2022.
- ÖZÇELİK, M. A., & AYCAN, A. (2022). EXPERIMENTAL INVESTIGATION OF SINGLE PHASE UNCONTROLLED RECTIFIERS. Prof. Dr. Yusuf ŞAHİN Prof. Dr. Adrian OLARU Assist. Prof. Senai YALÇINKAYA, 73.
- Salamena, V. (2020). SIMULATION OF UNCONTROLLED HALF-WAVE RECTIFIER USING SIMULINK MATLAB. *INTERNATIONAL JOURNAL OF MULTI SCIENCE*, 1(08), 96-104.
- Alzahrani, A. (2023). Experimental Investigation of Controlled and Uncontrolled Rectifiers for Low-Power Wind Turbines. *Applied Sciences*, 13(7), 4120.
- Nugraha, Anggara Trisna, and Rachma Prilian Eviningsih. *Penerapan Sistem Elektronika Daya: AC Regulator, DC Chopper, dan Inverter*. Deepublish, 2022.
- Zhang, Y., Wu, Y., Liu, C., Shen, Z., Wang, H., Pan, W., ... & Li, Z. (2022). Passive paralleling of multi-phase diode rectifier for wireless power transfer systems. *IEEE Transactions on Circuits and Systems II: Express Briefs*, 70(2), 646-649.
- Bidadfar, A., Saborío-Romano, O., Cutululis, N. A., & Sørensen, P. E. (2020). Control of offshore wind turbines connected to diode-rectifier-based HVdc systems. *IEEE Transactions on Sustainable Energy*, 12(1), 514-523.
- Nugraha, Anggara Trisna, et al. "Three Phase Controlled Rectifier Circuit for Characteristic Control in DC Shunt Motor." (2023).
- Li, R., & Xu, L. (2020). A unidirectional hybrid HVDC transmission system based on diode rectifier and full-bridge MMC. *IEEE Journal of Emerging and Selected Topics in Power Electronics*, 9(6), 6974-6984.
- As'ad, Reza Fardiyan, Salsabila Ika Yuniza, and Anggara Trisna Nugraha. "The Effect of 3 Phase Full Wave Uncontrolled Rectifier on 3 Phase AC Motor." *International Journal of Advanced Electrical and Computer Engineering* 3.2 (2022).
- Agna, Diego Ilham Yoga, Salsabila Ika Yuniza, and Anggara Trisna Nugraha. "The Single-Phase Controlled Half Wave Rectifier with Single-Phase Generator Circuit Model to Establish Stable DC Voltage Converter Result." *International Journal of Advanced Electrical and Computer Engineering* 3.3 (2022).

- Gawrylczyk, K. M., & Banaszak, S. (2021). Recent developments in the modelling of transformer windings. *Energies*, 14(10), 2798.
- Abbasi, A. R., Mahmoudi, M. R., & Arefi, M. M. (2021). Transformer winding faults detection based on time series analysis. *IEEE Transactions on Instrumentation and Measurement*, 70, 1-10.
- Moradnouri, A., Ardeshiri, A., Vakilian, M., Hekmati, A., & Fardmanesh, M. (2020). Survey on high-temperature superconducting transformer windings design. *Journal of Superconductivity and Novel Magnetism*, 33, 2581-2599.
- Li, Z., Zhang, Y., Abu-Siada, A., Chen, X., Li, Z., Xu, Y., ... & Tong, Y. (2021). Fault diagnosis of transformer windings based on decision tree and fully connected neural network. *Energies*, 14(6), 1531.
- Jabari, M., Ekinci, S., Izci, D., Bajaj, M., & Zaitsev, I. (2024). Efficient DC motor speed control using a novel multi-stage FOPD (1+ PI) controller optimized by the Pelican optimization algorithm. *Scientific Reports*, 14(1), 22442.
- Ma'arif, A., & Setiawan, N. R. (2021). Control of DC motor using integral state feedback and comparison with PID: simulation and arduino implementation. *Journal of Robotics and Control (JRC)*, 2(5), 456-461.
- Zhang, R., & Gao, L. (2022). The Brushless DC motor control system Based on neural network fuzzy PID control of power electronics technology. *Optik*, 271, 169879.
- Sami, S. S., Obaid, Z. A., Muhssin, M. T., & Hussain, A. N. (2021). Detailed modelling and simulation of different DC motor types for research and educational purposes. *International Journal of Power Electronics and Drive Systems (IJPEDS)*, 12(2), 703-714.
- Khalifa, M., Amhedb, A. H., & Al Sharqawi, M. (2021). Real time DC motor position control using PID controller in LabVIEW. *Journal of Robotics and Control (JRC)*, 2(5), 342-348.