

Performance Analysis of a Single-Phase Controlled Half-Wave Rectifier Applied to AC Motor

Imam Mursyid Muttaqin¹, Salsabila Ika Yuniza², Anggara Trisna Nugraha³

1,2,3 Marine Electrical Engineering, Shipbuilding Institute of Polytechnic Surabaya

¹ mursyidmuttaqin24@student.ppons.ac.id, ² salsabilaika@student.ppons.ac.id, ³ anggaranugraha@ppons.ac.id

Abstract

The rapid pace of industrial development is closely tied to the increasing demand for efficient material handling systems. Cranes, which are integral to the movement of products or goods, often rely on direct current (DC) motors for propulsion. Conventional methods of controlling these motors, which utilize fixed-voltage rectification powered by transformers, are still widely adopted. However, these traditional approaches suffer from several limitations, including the lack of flexibility in voltage regulation and the bulkiness and high costs associated with the transformer setup. This study presents an innovative solution by exploring the use of a fully controlled single-phase rectifier, leveraging the ICTCA785 integrated circuit for precise thyristor firing angle control. The rectifier's performance was evaluated with different load configurations, including resistive (R), resistive-inductive (R-L), and resistive-capacitive (R-C) loads, under varying conditions. A proportional-integral (PI) controller was employed to adjust the load voltage and current amplitude. The findings reveal that increasing the PI controller's gain results in higher amplitude of the load voltage and current, highlighting the importance of the controller's tuning in regulating the rectifier output. Furthermore, the study demonstrates that in certain configurations, the PI controller has minimal or no impact on the load voltage amplitude, depending on the specific rectifier design and load setup. The results underscore the significance of rectifier circuits in converting alternating current (AC) sine waves into stable DC pulses, which are fundamental for powering electronic devices and industrial systems. This research provides valuable insights into the practical application of fully controlled single-phase rectifiers, offering improvements in voltage regulation, efficiency, and flexibility, making them highly applicable in modern industrial automation and motor control systems.

Keywords: Inverter, Rectifier Circuit, Single Phase Rectifier

1. Introduction

In modern electrical systems, most electronic devices operate using standard AC power supplied by electrical utilities, typically at 220V/50Hz, as is common in many countries such as Indonesia (Nugraha & Eviningsih, 2022). While some smaller electronic devices, like radios, rely on batteries as their primary power source, a significant portion of industrial and domestic appliances are powered by the alternating current (AC) from the public grid. However, many electronic systems, especially in industrial automation and motor control, require a steady supply of direct current (DC). To achieve this, it is essential to convert the AC power to DC, and this process is commonly achieved through a rectifier circuit (Faj'riyah, Setiyoko, & Nugraha, 2021).

Rectifier circuits are crucial components in power supply systems, as they facilitate the conversion of alternating current (AC) into direct current (DC), which is necessary for powering a wide range of electronic equipment. A basic rectifier circuit typically consists of several key components: a transformer, diodes, and a capacitor. The transformer is used to either step down or step up the input voltage, adapting it for use in different applications. Capacitors play a critical role in smoothing out the rectified output, storing energy temporarily and filtering fluctuations in the voltage. Diodes, on the other hand, act as the core components in the rectification process, allowing current to flow in one direction while blocking reverse current, thus ensuring that only direct current flows to the load (Nugraha et al., 2023).

The type of rectifier circuit explored in this study is the single-phase half-wave controlled rectifier, which represents an essential step in converting the AC input into DC pulses required for the operation of various electrical devices. The importance of such experiments lies not only in their theoretical contributions but also in their practical applications across various industries, where they are used to power motors, automation systems, and electronic appliances (Agha, Yuniza, & Nugraha, 2022).

Furthermore, one of the advancements in rectifier technology is the bridge rectifier, which allows for a half-wave controlled rectifier design with a single-phase, two-wire input. This configuration is advantageous in reducing both the cost and the weight of the power supply system, compared to traditional rectifiers that require a three-wire transformer input with center-tapped secondary coils (As'ad, Yuniza, & Nugraha, 2022). The use

of a bridge rectifier enables a more compact and efficient solution for DC conversion in industrial and residential applications.

The theory of electric current flow, as initially outlined by Benjamin Franklin and largely adopted by engineers today, dictates that current flows from the anode to the cathode through a conductive material (Nugraha & Eviningsih, 2022). Although the direction of free electron flow in conductors is actually from the cathode to the anode, the conventional flow direction remains standard in engineering applications (Wibowo & Nugraha, 2023). In a single-phase half-wave rectifier, when the input voltage is positive at one end of the transformer, current flows through the load and returns through the other side of the transformer, creating a directional flow of current that is rectified into a DC output (Aгна, Sobhita, & Nugraha, 2023).

The application of these rectifier circuits is particularly relevant in the context of motor control, where they serve as a foundation for controlling the speed and torque of motors in various automation systems. In this study, the performance of a single-phase controlled half-wave rectifier is analyzed and tested with different load types, contributing to the optimization of power conversion in real-world industrial settings. These findings are expected to have a profound impact on improving the efficiency and cost-effectiveness of motor control systems used in industrial operations, where precise and stable DC power is critical.

2. Material and methods

2.1. Material

A. Diode

A diode is a semiconductor device that has two terminals: the anode and the cathode. It functions as a one-way valve for electric current, allowing current to flow in only one direction. When the anode is more positively charged than the cathode, the diode is in the forward bias state, and current flows freely from the anode to the cathode (As'ad & Nugraha, 2022) (Bui, Nguyen, & Seo, 2023). This behavior is essential in rectifier circuits where diodes are used to convert alternating current (AC) into direct current (DC), as they effectively block reverse current flow.

Conversely, when the cathode is more positively charged than the anode, the diode enters the reverse bias state, preventing current from flowing from the cathode to the anode (Bidadfar, Saborío-Romano, Cutululis, & Sørensen, 2020). This property of the diode is crucial in maintaining the directional flow of current within rectifier circuits, ensuring that only the desired portion of the AC waveform is allowed to pass through (Handandi et al., 2023).

However, the diode has an inherent limitation known as the breakdown voltage or reverse breakdown voltage (Li & Xu, 2020). This is the maximum reverse voltage that the diode can withstand before it begins to conduct current in the reverse direction, potentially leading to permanent damage or failure of the diode (Yu, Xu, Zhu, & Li, 2021). The breakdown voltage is a critical parameter in the design of power electronic circuits, particularly in high-voltage applications such as motor control systems, where diodes must operate reliably within their specified voltage ratings to prevent malfunction (Wu et al., 2021).

In the context of single-phase controlled half-wave rectifiers used in AC motor control, understanding the behavior of diodes under both forward and reverse bias conditions is essential. The performance and reliability of these circuits depend significantly on the proper selection and operation of diodes within their rated breakdown voltage limits, ensuring efficient and stable operation of the motor drive systems in industrial applications.

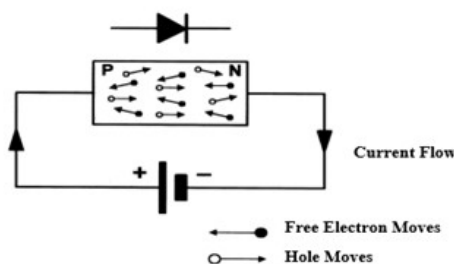

Figure 1. The working principle and form of the diode circuit

B. Wave Rectifier / Rectifier

A rectifier is a critical component in power supply systems, designed to convert alternating current (AC) voltage signals into direct current (DC) voltage. This conversion process is fundamental in many electronic applications, especially in power electronic systems that require a stable and controlled DC supply. A controlled rectifier, also known as a converter, is a power electronics circuit that facilitates the transformation of sinusoidal AC voltage into a controlled DC output. The use of controlled rectifiers is essential for achieving precise voltage regulation, which is crucial in various industrial applications such as motor drives, power supplies, and renewable energy systems (Safari, Barile, Stornelli, & Ferri, 2020).

In controlled rectification, one of the key components used to regulate the output voltage is the thyristor. The thyristor is a semiconductor device capable of controlling the flow of current based on its ignition angle. By varying the firing angle or triggering angle of the thyristor, the output voltage can be dynamically adjusted, making it possible to obtain a controlled DC voltage from an AC input (Yildirim, 2021). This control mechanism is especially valuable in systems where the voltage must be modulated to meet specific operational requirements, such as in AC motor speed control or voltage regulation in industrial applications.

The three-phase thyristor rectifier is a commonly used configuration in power electronics, particularly in industrial motor control and high-power applications. This setup consists of six thyristors (Q1, Q2, Q3, Q4, Q5, and Q6) arranged in a specific manner. The cathodes of thyristors Q1, Q3, and Q5 are connected to the positive terminal, while the anodes of thyristors Q2, Q4, and Q6 are connected to the negative terminal of the circuit. Each thyristor is triggered by a distinct ignition pulse (U_{G1} , U_{G2} , U_{G3} , U_{G4} , U_{G5} , U_{G6}), which determines the conduction period and, consequently, the output DC voltage. This configuration is particularly effective in driving resistive loads (R_L) and is frequently utilized in systems where the load characteristics require smooth and regulated DC output (Leuw et al., 2022).

The study of these rectifiers and their control mechanisms is vital for optimizing power conversion systems and ensuring their reliability and efficiency in modern engineering applications, such as in industrial motor drives and renewable energy integration. Analyzing the performance of controlled rectifiers, particularly in relation to their ability to regulate voltage for different load types, is crucial for enhancing the functionality of motor control systems used in sectors like manufacturing, automation, and transportation.

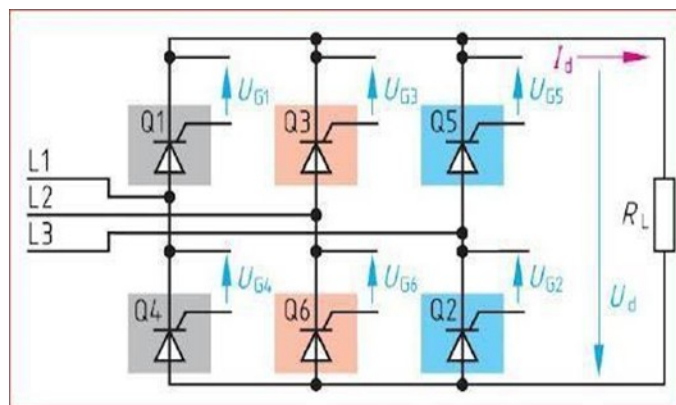

Figure 2. The working principle and form of the rectifier circuit

C. Half wave converter

The topology of a three-phase half-wave converter is illustrated in Figure 1, which highlights the operational sequence of the thyristors and the corresponding phase voltages across the load. In this configuration, when thyristor T1 is triggered at $t = \pi/6+$, the phase voltage V_{an} appears across the load, sustaining current flow until thyristor T2 is activated at $t = 5\pi/6+$. At this point, T1 becomes reverse biased because the source voltage, $V_{ab} = V_{an} - V_{bn}$, turns negative, causing T1 to turn off and effectively cease conduction.

When thyristor T2 is activated, the phase voltage V_{bn} is applied across the load, continuing until thyristor T3 is triggered at $t = 3\pi/2+$. With T3 in conduction, T2 is deactivated, and the phase voltage V_{cn} is now supplied to the load. This cycle repeats, with T1 once again being triggered at the beginning of the next cycle. This sequence of thyristor activation ensures that the AC voltage is effectively rectified to a controlled DC output, with each phase voltage appearing sequentially across the load at specific time intervals.

The output voltage of a single-phase half-wave controlled rectifier can be described as a fraction of the maximum peak voltage V_{max} (V_{peak}) of the AC supply, modified by the ignition angle of the triggering pulses. Specifically, the output voltage is given by:

$$V_{out} = V_{max} / 2\pi + \text{function of firing angle } (\alpha)$$

This equation reflects how the rectifier's output voltage is directly related to the peak voltage of the AC cycle, as well as the controlled firing angle of the thyristors. The ability to modulate the firing angle is key in adjusting the output voltage to meet specific operational requirements, such as in AC motor speed control or power regulation in industrial systems. The performance analysis of such controlled rectifiers plays a critical role in improving power conversion efficiency and ensuring the stability of DC motor drives in various applications, particularly in automation, manufacturing, and electrical power distribution systems (Rotenberg et al., 2020) (Xu et al., 2022).

Output DC Voltage:

$$V_{0(DC)} = \frac{1}{2\pi} \int_0^\pi V_m \sin(\omega t) d(\omega t)$$

$$V_{0(DC)} = \frac{V_m}{2\pi} [1 + \cos\alpha] = \frac{V_s(max)}{2\pi} [1 + \cos\alpha]$$

And Output RMS Voltage is:

$$V_{0(rms)} = \sqrt{\frac{1}{2\pi} \int_0^\pi V_m^2 \sin^2(\omega t) d(\omega t)}$$

$$V_{0(rms)} = \frac{V_s(max)}{2\pi} \sqrt{1 - \frac{\alpha}{\pi} + \frac{\sin(2\alpha)}{2\pi}}$$

RMS Current:

$$I_{rms} = \frac{V_{rms}}{R} \text{ with ripple factor } RF = \sqrt{FF^2 - 1}$$

To calculate the output power, the following equation is used:

$$P_{rms} = V_{rms} \times I_{rms}$$

$$P_{dc} = V_{dc} \times I_{dc} [14]$$

2.2. Methods

The type of research used in this research is quantitative research with experimental methods. The experimental method is carried out by designing, making, and testing tools (measurements). [15]

The block diagram of a controlled rectifier can be broadly divided into 3 blocks, namely the trigger circuit block from the transformer, the 1 phase half wave converter from the rectifier and the 1 phase filter as follows: [15]

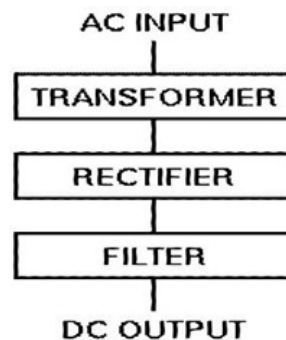

Figure 3. Block diagram of the rectifier circuit

A. Principle of 1 phase half wave-controlled rectifier

Figure (4) shows when the controlled rectifier is loaded resistively. During the positive half cycle of the input voltage, the anode of the SCR is positive relative to the cathode so that the SCR is forward biased. When SCR T1 is turned on at $t =$, SCR T1 will be connected and current will flow to the load. When the input voltage starts to be negative at $t =$, the anode of the SCR will be negative with respect to the cathode and the SCR T1 will be said to be reverse biased and no current will flow to the load. The trigger circuit is planned with an input voltage of 50 Vac, thus R min is calculated by calculating the value of 3.3 k Ω . The value of the capacitor is determined at 0.1 μ F 100 V thus the circuit is as follows:[10]

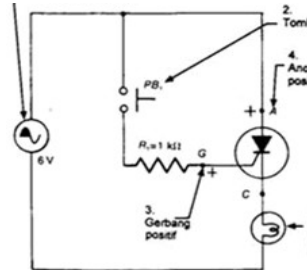

Figure 4. Single Phase Half-Wave Rectifier Circuit.

The snubber circuit is basically a safety circuit for the semiconductor components used in rectifiers, namely diodes and SCR overvoltage, which may arise during the reverse recovery process. Based on the calculation, the value = 220.

The time when the input voltage is positive until the thyristor is turned on at $\omega t =$ is called the delay angle or ignition angle[16]. When these two alternating signals are out of phase with each other, the two diodes, each acting as a half-wave rectifier, can operate alternately. A diode that rectifies the positive cycle of the top coil and then replaces the positive cycle rectifier of the bottom coil as the reverse phase of the negative cycle of the AC input signal.[8]

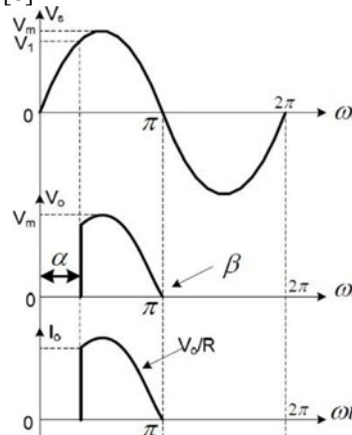

Figure 5. Waveform of Single-Phase Half-Wave Rectifier

The output of a controlled rectifier is 1 phase half-wave thicker than a half-wave rectifier, which reduces the ripple present in the DC voltage output. As a result, the output of a half-wave 1-phase controlled rectifier is smoother and more stable than the output of a half-wave rectifier. It can be said that the calculation of the DC voltage in a 1-phase half- wave-controlled rectifier is twice that of a half-wave rectifier. This is because all AC signal cycles are output.

Then for the circuit form using PSIM which will be used in this research as follows:

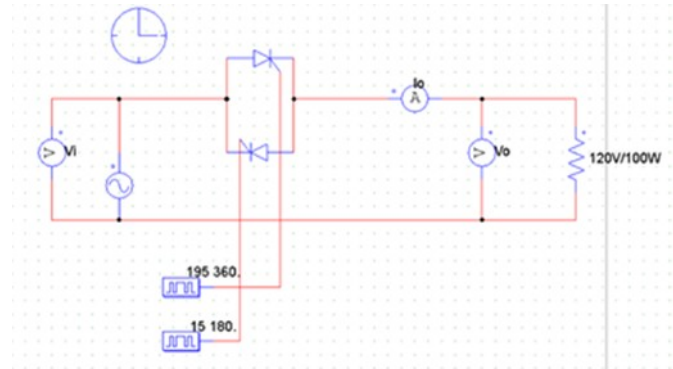

Figure 6. Single Phase Half-Wave Rectifier Circuit with Single Phase AC Motor Load.

3. Results and discussion

The simulation results are used to validate the design results. This verification is intended to test the design results according to the characteristics of the components or devices used to minimize design and manufacturing errors. [17] The following figure shows the simulation results of the trigger circuit design. This trigger circuit basically examines the characteristics of the DIAC. Based on the picture below, the design result has the same characteristics as the diac. Therefore, it can be properly designed and manufactured[19].

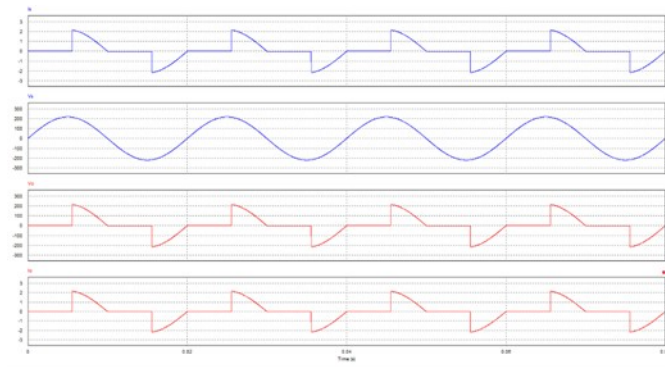

Figure 7. Graphics Output of Single Phase Half Wave Rectifier with Motor Load.

The calculation of the simulation results is used to validate the output design results of the Single Phase Half-Wave Rectifier with Load as follows:

1. Average value of DC voltage dan DC current:

a. DC voltage with the value of α 15

$$V_{0(DC)} = \frac{V_m}{2\pi} [1 + \cos\alpha] = \frac{V_s(max)}{2\pi} [1 + \cos\alpha]$$

$$V_{0(DC)} = \frac{220}{2(3,14)} [1 + 0,96] = \frac{220}{6,28} [1,96] \\ = 68,66 \text{ volt}$$

b. DC Current for α 15

$$I_o(DC) = V_o(DC) / R \\ = 68,66 / 100 \\ = 0,68$$

2. Average value of DC voltage dan DC current:

a. DC voltage with the value of α 30

$$V_{0(DC)} = \frac{V_m}{2\pi} [1 + \cos\alpha] = \frac{V_s(max)}{2\pi} [1 + \cos\alpha]$$

$$V_{0(DC)} = \frac{220}{2(3,14)} [1+0,86] = \frac{220}{6,28} [1,86] \\ = 65,37 \text{ volt}$$

b. DC Current for α 30

$$I_o (DC) = V_o (DC) / R \\ = 65,37 / 100 \\ = 0,65$$

3. Average value of DC voltage dan DC current:

a. DC voltage with the value of α 45

$$V_{0(DC)} = \frac{Vm}{2\pi} [1+\cos\alpha] = \frac{Vs(max)}{2\pi} [1+\cos\alpha] \\ V_{0(DC)} = \frac{220}{2(3,14)} [1+0,70] = \frac{220}{6,28} [1,70] \\ = 59,80 \text{ volt}$$

b. DC Current for α 45

$$I_o (DC) = V_o (DC) / R \\ = 59,80 / 100 \\ = 0,59$$

4. Average value of DC voltage dan DC current:

a. DC voltage with the value of α 60

$$V_{0(DC)} = \frac{Vm}{2\pi} [1+\cos\alpha] = \frac{Vs(max)}{2\pi} [1+\cos\alpha] \\ V_{0(DC)} = \frac{220}{2(3,14)} [1+0,50] = \frac{220}{6,28} [1,50] \\ = 52,50 \text{ volt}$$

b. DC Current for α 45

$$I_o (DC) = V_o (DC) / R \\ = 52,50 / 100 \\ = 0,52$$

5. Average value of DC voltage dan DC current:

a. DC voltage with the value of α 75

$$V_{0(DC)} = \frac{Vm}{2\pi} [1+\cos\alpha] = \frac{Vs(max)}{2\pi} [1+\cos\alpha] \\ V_{0(DC)} = \frac{220}{2(3,14)} [1+0,25] = \frac{220}{6,28} [1,25] \\ = 44,0 \text{ volt}$$

b. DC Current for α 75

$$I_o (DC) = V_o (DC) / R \\ = 44,0 / 100 \\ = 0,44$$

6. Average value of DC voltage dan DC current:

a. DC voltage with the value of α 90

$$V_{0(DC)} = \frac{Vm}{2\pi} [1+\cos\alpha] = \frac{Vs(max)}{2\pi} [1+\cos\alpha]$$

$$V_{0(DC)} = \frac{220}{2(3,14)} [1+0] = \frac{220}{6,28} [1] \hat{i}$$

$$= 35 \text{ volt}$$

b. DC Current for α 45

$$I_o (DC) = V_o (DC) / R$$

$$= 35 / 100$$

$$= 0,35$$

7. Average value of DC voltage dan DC current:

a. DC voltage with the value of α 100

$$V_{0(DC)} = \frac{Vm}{2\pi} [1+\cos\alpha] = \frac{Vs(max)}{2\pi} [1+\cos\alpha] \hat{i}$$

$$V_{0(DC)} = \frac{220}{2(3,14)} \hat{i} [0,83] \hat{i}$$

$$= 29,0 \text{ volt}$$

b. DC Current for α 100

$$I_o (DC) = V_o (DC) / R$$

$$= 29 / 100$$

$$= 0,29$$

2. PAC input power and PDC output power

Then for the result of the Pdc output output power

Table 1. Result Pdc output

Vs(rms) (L-N) (Volt)	α	Vo(dc) (Volt)	Is(dc) (A)	Po(dc) (W)
25	15	140	1,40	196
25	30	130	1,30	169
25	45	119	1,19	141
25	60	105	1,05	110
25	75	88	0,88	77
25	90	69	0,69	47
25	100	57	0,57	32

Based on the input power V_o , it can be seen that its effect on Pdc can be illustrated in the bar chart as follows: From the experiment above, it can be concluded that the value of α affects the output of both $V_o(DC)$, $I_o(DC)$, $I_o(RMS)$ and $V_o(RMS)$ where:

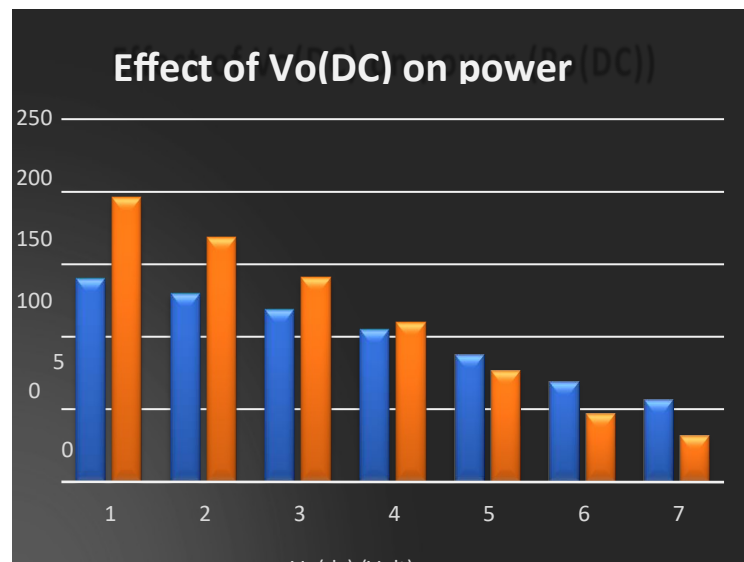

Figure 8. Graph result

- a. The value of a will make the value of $V_o(\text{DC})$ and $I_o(\text{DC})$ inversely proportional to the magnitude of $V_o(\text{DC})$ and $I_o(\text{DC})$ where if the value of a is greater then the value of $V_o(\text{DC})$ and $I_o(\text{DC})$ will be smaller.
- b. The value of a will make the value of $I_o(\text{RMS})$ and $V_o(\text{RMS})$ inversely proportional to the magnitude of $I_o(\text{RMS})$ and $V_o(\text{RMS})$ where if the value of a is greater then the value of $I_o(\text{RMS})$ and $V_o(\text{RMS})$ will be smaller.
- c. The value of a will make the value of the output power ($P_o(\text{dc})$) constant with the voltage and current sources of the circuit.

4. Conclusion

1. In the context of power electronics, rectifier diodes serve a critical role as wave rectifiers, which are essential for converting alternating current (AC) voltage into direct current (DC) voltage. This conversion process is fundamental for the operation of various electronic devices and systems, as well as for ensuring the stable and efficient supply of DC power for applications such as motor drives, industrial machinery, and sensitive electronic equipment. The performance of such circuits is heavily influenced by the diode characteristics and the rectifier configuration, with three-phase rectifiers offering superior efficiency and lower ripple compared to single-phase systems.
2. The study reveals that using a Proportional-Integral (PI) controller in a single-phase controlled rectifier without feedback does not significantly impact the magnitude of the load voltage or the current amplitude. This indicates that the system cannot efficiently control the voltage or current amplitude under such conditions, highlighting the need for more sophisticated control strategies in systems where precise power regulation is required. The absence of feedback in the control loop restricts the rectifier's ability to adapt to load variations, underscoring the importance of implementing closed-loop control systems for better performance in AC motor speed control and power conversion applications.
3. The output voltage in an unfiltered rectifier can be derived from the standard equations that govern a half-wave rectifier. In a single-phase half-wave controlled rectifier, these equations are applied to determine the magnitude of the output voltage. Additionally, the magnitude of voltage ripple in a filtered rectifier can be predicted using the same principles that apply to half-wave rectifiers. Despite the differences in circuit configurations, these findings emphasize the significance of proper filtering techniques to minimize ripple, which directly affects the DC output quality and overall system stability. This analysis is crucial for understanding the behavior of single-phase rectifiers in both unfiltered and filtered states, particularly for power supply design and motor control applications.
4. When a single-phase feedback-controlled rectifier is tested with different load types, such as resistive (R), resistive-inductive (R-L), and resistive-capacitive (R-C) loads, it is observed that the amplitude of the load voltage and current can be effectively controlled by adjusting the PI controller settings. The proportional-integral (PI) controller plays a crucial role in regulating the voltage and current by compensating for load fluctuations and ensuring the rectifier operates within desired parameters. The experimental results show that an increase in the PI controller's proportional gain leads to a rise in the amplitude of both the load voltage and current, providing valuable insights into the design of more adaptive and responsive control systems for applications in industrial power conversion and motor speed regulation.
5. In the case of a single-phase controlled rectifier connected to an R-L-C load, the output voltage and current amplitudes become relatively fixed, meaning that variations in the PI controller settings have a diminished impact on the load characteristics. This suggests that, for more complex load configurations, such as R-L-C combinations, the controller's influence on the output becomes less significant, especially when the system operates within a predefined range of parameters. These findings indicate the necessity of considering load dynamics and control strategies that can adapt to various load types and ensure efficient performance across a broad spectrum of engineering applications, particularly in motor control and power electronics.

Credit authorship contribution statement

Author Name: Conceptualization, Writing – review & editing. **Author Name:** Supervision, Writing – review & editing. **Author Name:** Conceptualization, Supervision, Writing – review & editing.

References

- Nugraha, Anggara Trisna, and Rachma Prilian Eviningsih. Konsep Dasar Elektronika Daya. Deepublish, 2022.
- Faj'riyah, Annisa Nur, Annas Singgih Setiyoko, and Anggara Trisna Nugraha. "Rancang Bangun Prototipe Proteksi Motor Terhadap Overheat Serta Monitoring Arus dan Tegangan Berbasis Arduino Uno." *Elektriase: Jurnal Sains dan Teknologi Elektro* 11.01 (2021): 20-25.
- Nugraha, Anggara Trisna, et al. "Three Phase Controlled Rectifier Circuit for Characteristic Control in DC Shunt Motor." (2023).
- Agna, Diego Ilham Yoga, Salsabila Ika Yuniza, and Anggara Trisna Nugraha. "The Single-Phase Controlled Half Wave Rectifier with Single-Phase Generator Circuit Model to Establish Stable DC Voltage Converter Result." *International Journal of Advanced Electrical and Computer Engineering* 3.3 (2022).
- As'ad, Reza Fardiyan, Salsabila Ika Yuniza, and Anggara Trisna Nugraha. "The Effect of 3 Phase Full Wave Uncontrolled Rectifier on 3 Phase AC Motor." *International Journal of Advanced Electrical and Computer Engineering* 3.2 (2022).
- Nugraha, Anggara Trisna, and Rachma Prilian Eviningsih. Penerapan Sistem Elektronika Daya: AC Regulator, DC Chopper, dan Inverter. Deepublish, 2022.
- As' ad, Reza Fardiyan, and Anggara Trisna Nugraha. "Rancang Bangun Penstabil Kinerja Panel Hubung Bagi Tegangan Rendah." *Journal of Computer, Electronic, and Telecommunication (COMPLETE)* 3.1 (2022).
- Handandi, Zukhruf Zidane, et al. "HOW THE PERFORMANCE OF A DC MOTOR SYSTEM IS IMPACTED BY NOISE." *Jurnal Teknologi Maritim* 6.1 (2023): 11-16.
- Wibowo, Muhammad Ferdiansyah, and Anggara Trisna Nugraha. "PERENCANAAN SISTEM PROPULSI ELEKTRIK PADA FAST PATROL BOAT 28 METER." *Proceedings Conference on Marine Engineering and its Application*. Vol. 6. No. 1. 2023.
- Agna, Diego Ilham Yoga, Rama Arya Sobhita, and Anggara Trisna Nugraha. "Penyearah Gelombang Penuh 3 Fasa Tak Terkendali dari Generator Kapal AC 3 Fasa." *Seminar MASTER PPNS*. Vol. 8. No. 1. 2023.
- Bui, G. T., Nguyen, D. A., & Seo, C. (2023). A novel design of dual-band inverse class-F shunt-diode rectifier for energy harvesting. *IEEE Transactions on Circuits and Systems II: Express Briefs*, 70(7), 2345-2349.
- Bidadfar, A., Saborío-Romano, O., Cutululis, N. A., & Sørensen, P. E. (2020). Control of offshore wind turbines connected to diode-rectifier-based HVdc systems. *IEEE Transactions on Sustainable Energy*, 12(1), 514-523.
- Li, R., & Xu, L. (2020). A unidirectional hybrid HVDC transmission system based on diode rectifier and full-bridge MMC. *IEEE Journal of Emerging and Selected Topics in Power Electronics*, 9(6), 6974-6984.
- Yu, L., Xu, L., Zhu, J., & Li, R. (2021). Impedance modelling and stability analysis of diode-rectifier based HVDC connected offshore wind farms. *IEEE Transactions on Power Delivery*, 37(1), 591-602.
- Wu, Y., Zhang, L., Zhou, Y., Hu, Z., Zhao, X., & Zhuang, Q. (2021, December). A hybrid HVDC converter based on MMC and diode rectifier for offshore wind farm integration. In *2021 International Conference on Power System Technology (POWERCON)* (pp. 1476-1480). IEEE.
- Safari, L., Barile, G., Stornelli, V., & Ferri, G. (2020). A new versatile full wave rectifier using voltage conveyors. *AEU-International Journal of Electronics and Communications*, 122, 153267.
- Yildirim, M. (2021). Design of low-voltage and low-power current-mode DTMOS transistor based full-wave/half-wave rectifier. *Analog Integrated Circuits and Signal Processing*, 106(2), 459-465.
- Leuw, B., Geng, J., Rice, J. H., Moseley, D. A., & Badcock, R. A. (2022). A half-wave superconducting transformer-rectifier flux pump using J c (B) switches. *Superconductor Science and Technology*, 35(3), 035009.
- Rotenberg, S. A., Podilchak, S. K., Re, P. D. H., Mateo-Segura, C., Goussetis, G., & Lee, J. (2020). Efficient rectifier for wireless power transmission systems. *IEEE Transactions on Microwave Theory and Techniques*, 68(5), 1921-1932.
- Xu, Z., Khalifa, A., Mittal, A., Nasrollahpourmotlaghzanjani, M., Etienne-Cummings, R., Sun, N. X., ... & Shrivastava, A. (2022). Analysis and design methodology of rf energy harvesting rectifier circuit for ultra-low power applications. *IEEE open journal of circuits and systems*, 3, 82-96.